

# Walking backwards – the control system needed to run Shor's algorithm on a fault tolerant computer

# Racing to Quantum Advantage

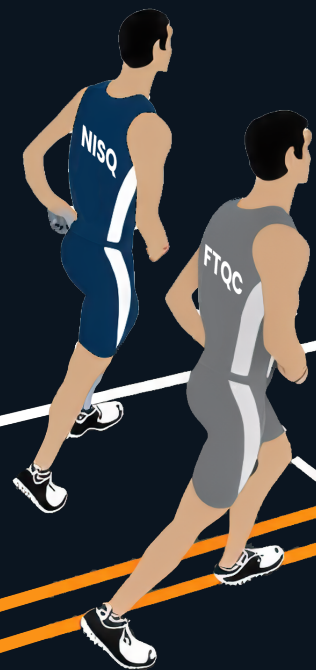

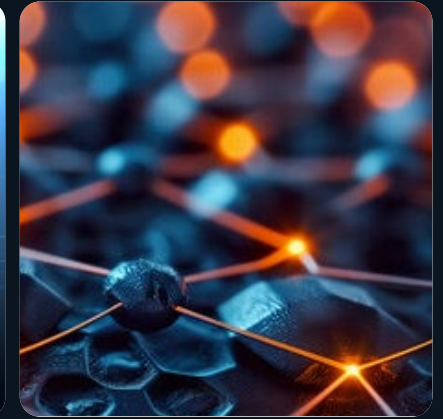

**99.9 %**  
Fidelity

$\sim 10^{-3}$   
Error rate for the  
best qubits to date



Quantum Error  
Correction

*Super - polynomial advantage  
estimated to require*  
>  $10^3$  qubits  
>  $10^8$  operations

**99.9999999999 %**  
Fidelity

**error rate  $\sim 10^{-11}$**

Among the biggest quantum computing companies globally

**160+ EMPLOYEES**  
**in 12 COUNTRIES**

Among the most well-funded quantum companies worldwide

**\$1.0M+**



Global technology pioneer  
**65+ PATENTS**



Establishing the Israeli  
Quantum Computing Center



**M&A**

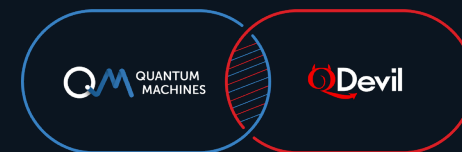

Industry - wide customer base

**300+ Customers**  
**in 20+ Countries**

Enterprises

Startups

National

Academic

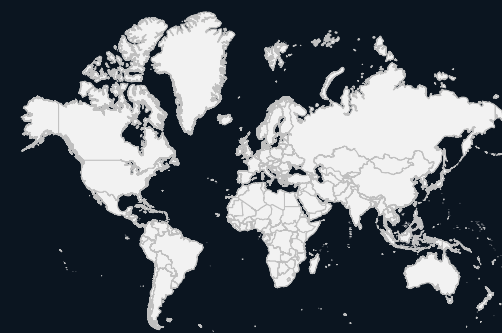

# Control solutions trusted to enable groundbreaking results

## Room Temperature Quantum Control Solutions

### OPX1000

High-density, modular quantum controller

### QDAC- II Compact

High-density DAC

### QSwitch

Remote-controlled breakout box

### QDAC- II

Ultra-low noise 24 channel DAC

### OPX+

Ultra-fast controller

### Octave

Up/down converter up to 18GHz



Most complete platform for advanced quantum control:

Highest channel density with world - best synchronization

Unmatched analog specs and real-time compute capabilities

## Cryogenic Sample Holders, Packaging and Filtering Solutions

World - best performance through the stack:

Optimized packaging enabling millisecond coherence

Best-in-class insertion losses, transmission and shielding



### QFilter

Compact multi-stage low-pass cryogenic filter

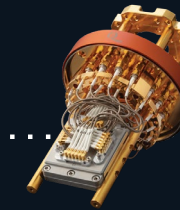

### Qcage.24 & .64

MW cavity sample holders

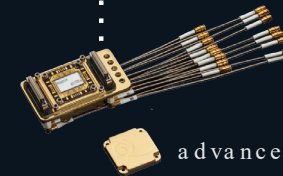

### QBoard - II

Non-magnetic advanced sample holder

2023-2024 Scientific Throughput

Science 8x nature  
nature portfolio  
Articles

6x 23x 60+

## Ease-of-use

- ✓ Modular: Mix & match baseband & MW
- ✓ Intuitive pseudo-like programming
- ✓ Out-of-the-box workflows for ultra-fast calibration and real-time retuning
- ✓ Simple to set up: multi-qubit calibration & RB in 48 hours from unboxing

- ✓ Effortlessly add units with any topology, data-sharing, exceptional phase synchronization, and no software redesign
- ✓ Supports 1000s channels with extremely high density of 26.7 channels/U
- ✓ NVIDIA - QM: Native GPU-quantum HW integration, roundtrip delay < 4  $\mu$ s

## Unrivaled scalability

## Processor - based controller

- ✓ Unmatched real-time compute and control-flow
- ✓ Ultra-fast feedback: active reset < 120 ns
- ✓ Enables the most advanced dynamic sequences right out of the box

- ✓ Direct Synthesis (DDS) technology up to 10.5 GHz
- ✓ Outstanding purity and SFDR (cannot be achieved with mixers/double heterodyne calibration)
- ✓ Baseband module with up to 16 multiplexed tones & Microwave module with 8 tones 2 carriers per channel
- ✓ 2 GSa/s and 4 GSa/s modes

## Cutting - edge analog specs

builders of the world  
most advanced quantum controller

OPX1000



QM's Processor-Based Controller

## of - use

V modules as needed

ke programming

orkflows for ultra - fast  
l - time retuning

**B in 48 hours** from

its with any to -  
exceptional  
tion, and no

annels with extremely  
**7 channels/U**

e GPU - quantum HW  
rip delay < 4  $\mu$ s

## scalability



# OPX1000



# WHY?

## Processor -

- ✓ Unmatched control-flow
- ✓ Ultra-fast feedback
- ✓ Enables the sequences j

- ✓ Direct Synthesis 10.5 GHz
- ✓ Outstanding performance be achieved with heterodyne
- ✓ Baseband multiplexed with 8 tones
- ✓ 2 GSa/s and

## Cutting ana

# Factoring the number 21 with QEC

$$21 = X \cdot Y$$

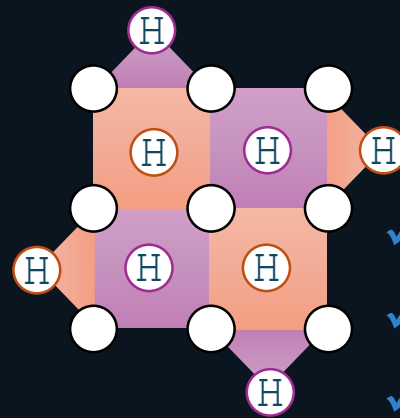

- ✓ 5 computational superconducting - qubits
- ✓ Surface - code
- ✓  $d=5$  ('distance 5')



Ease of use

Controller

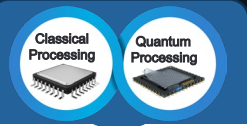

Processor - based Controller

$$21 = X \cdot Y$$



Unrivalled Scalability

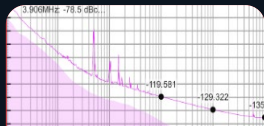

Cutting - edge Analog Specs

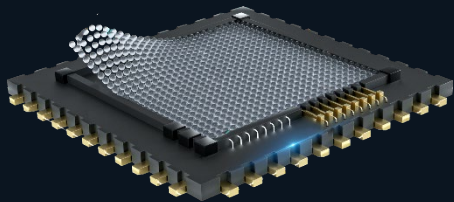

QPU

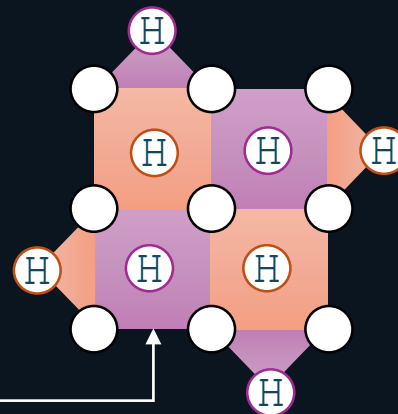

Original logical circuit ①

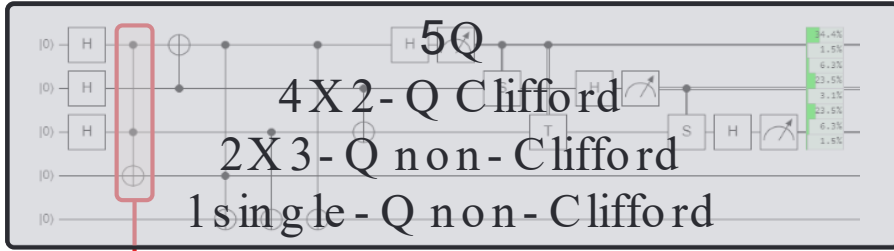

①.5 Surface-code compatible circuit

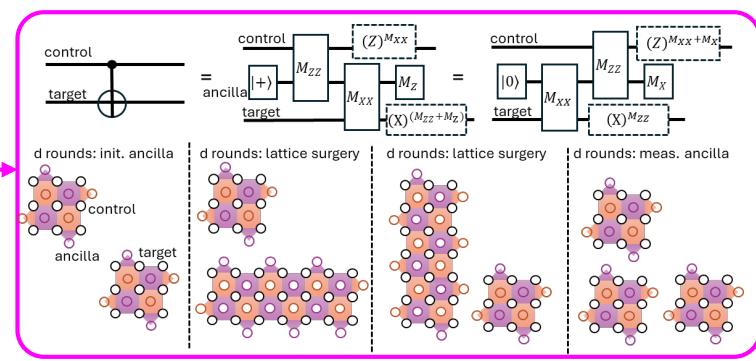
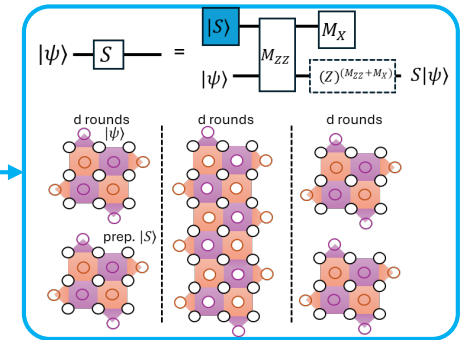
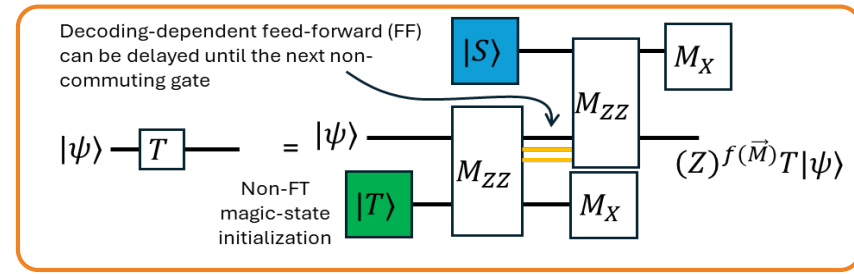
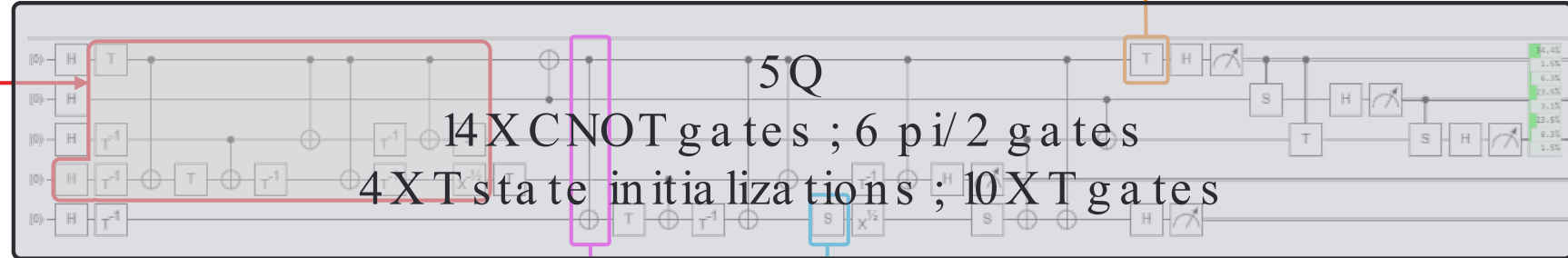

Original logical circuit 1

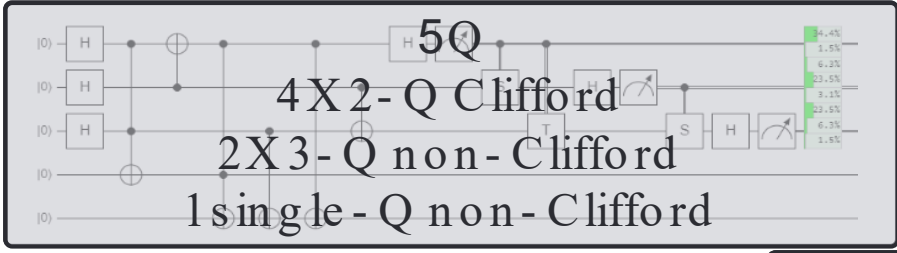

1.5 Surface-code compatible circuit

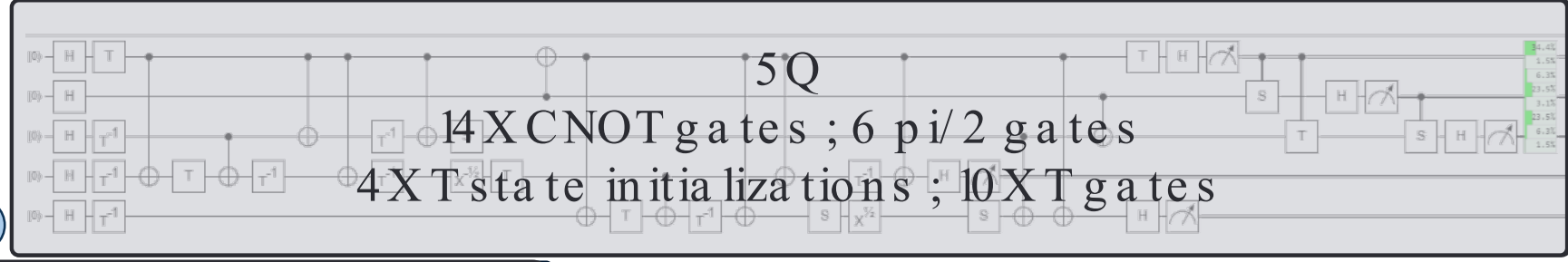

Surface-level circuit 2

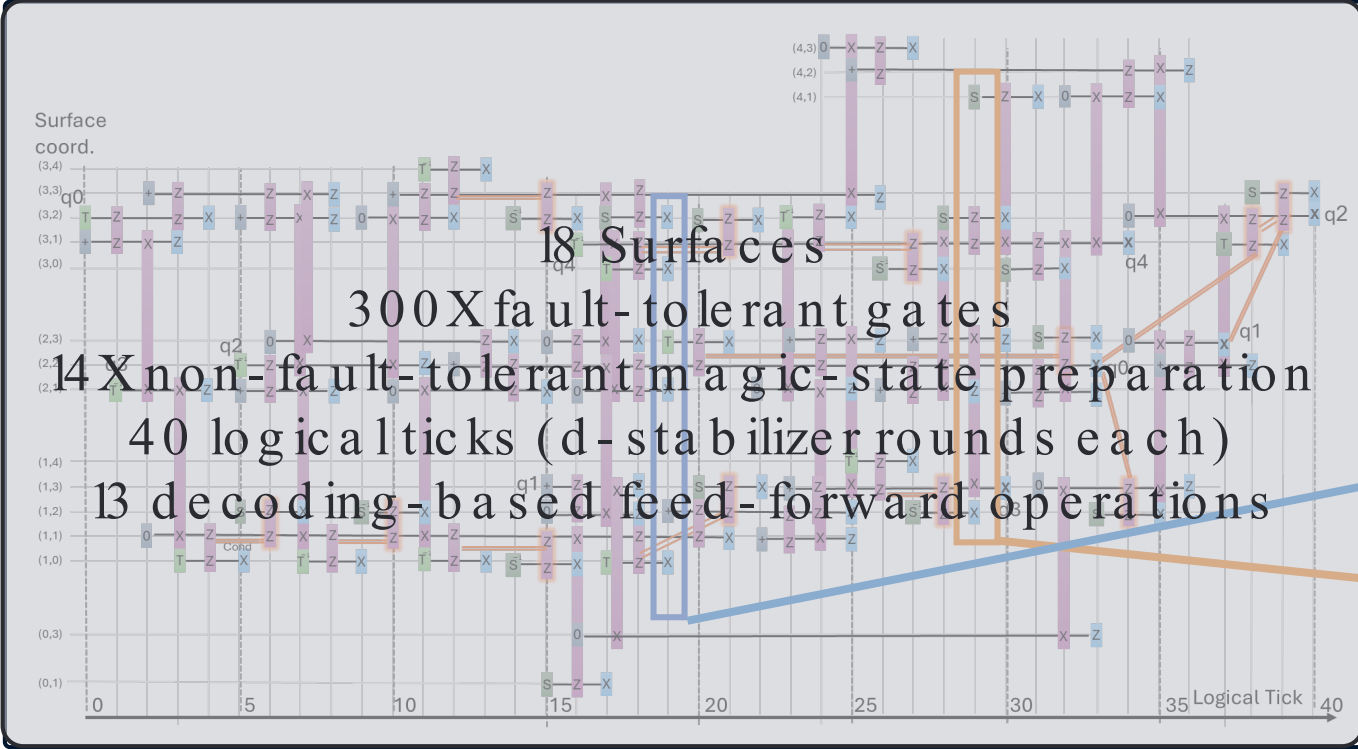

Physical-level circuit (partial) 3

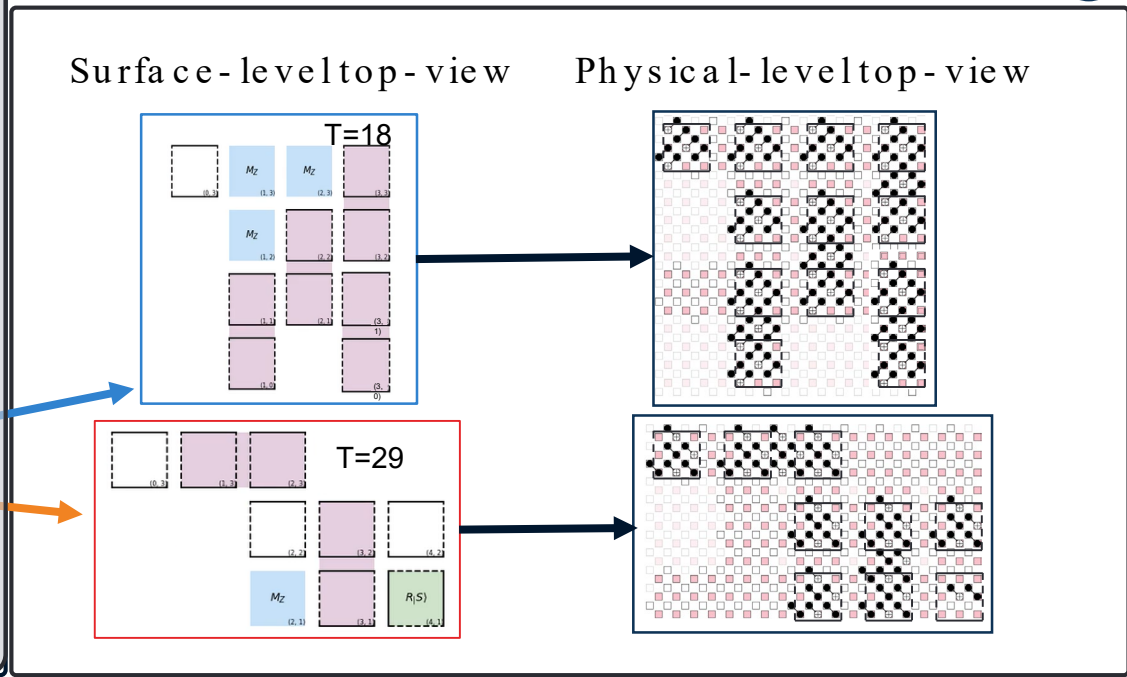

Original logical circuit 1

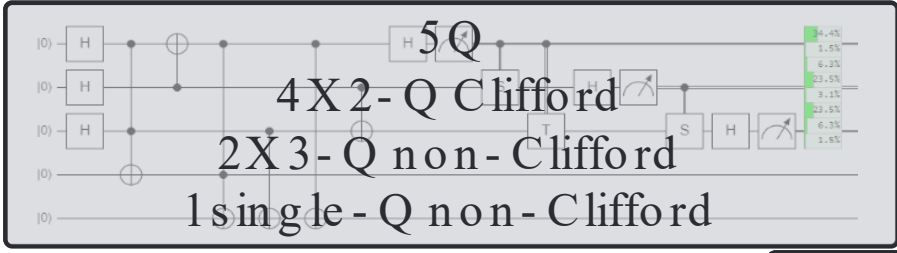

2 Surface-code compatible circuit

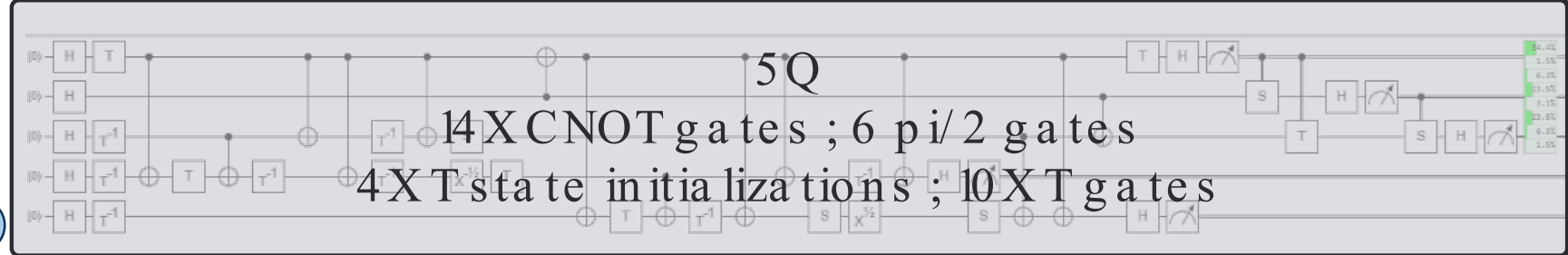

3 Surface-level circuit

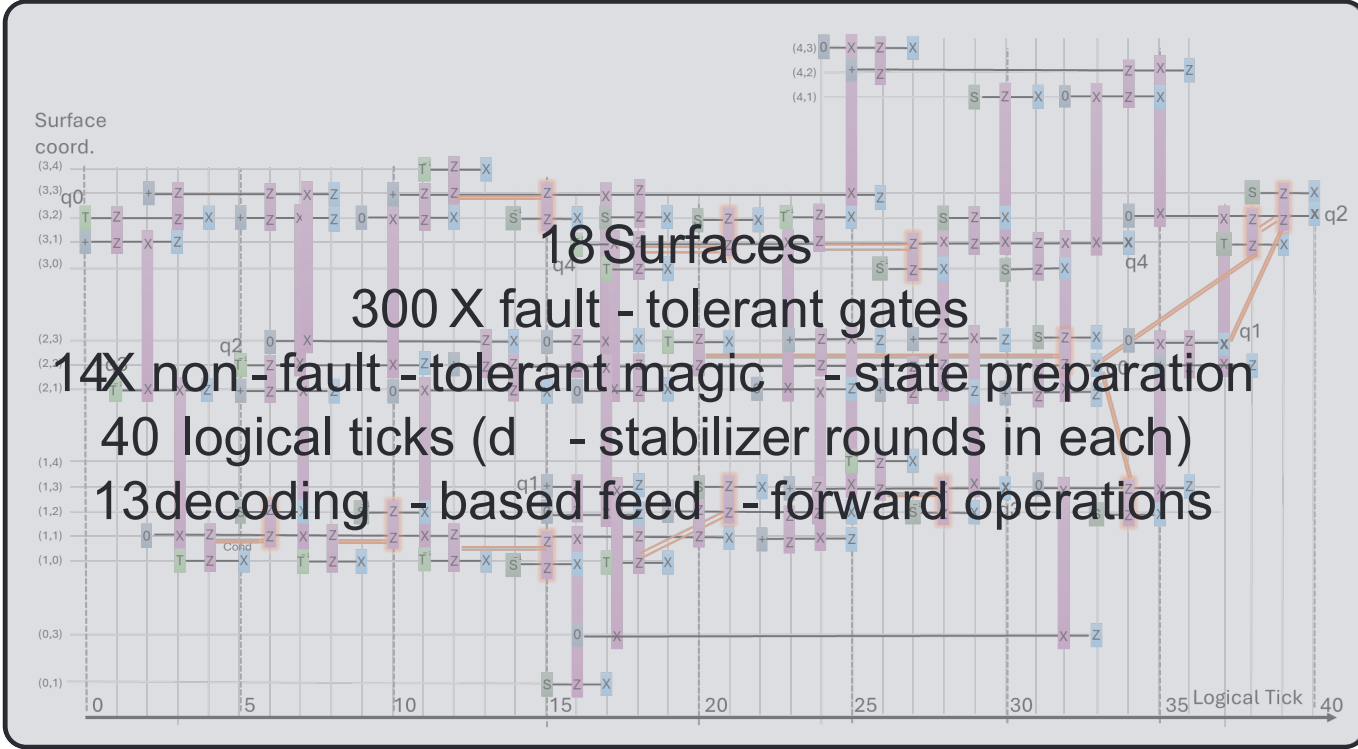

4 Physical-level circuit (partial)

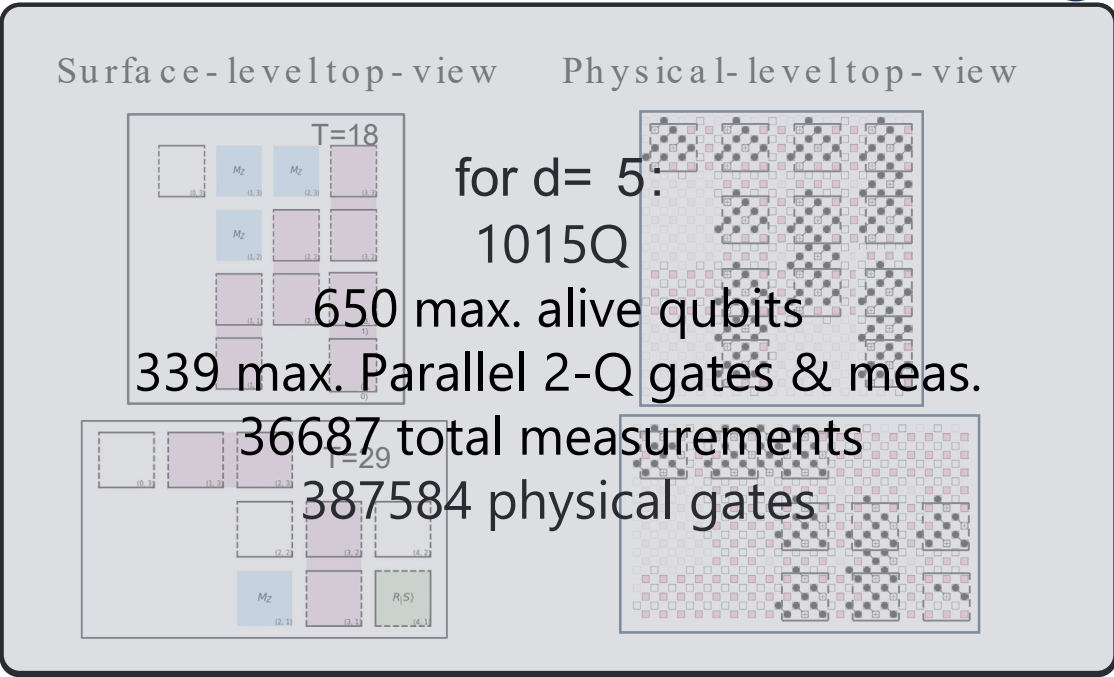

# Factoring 21 (with 90% success rate)

## 1 Logical level

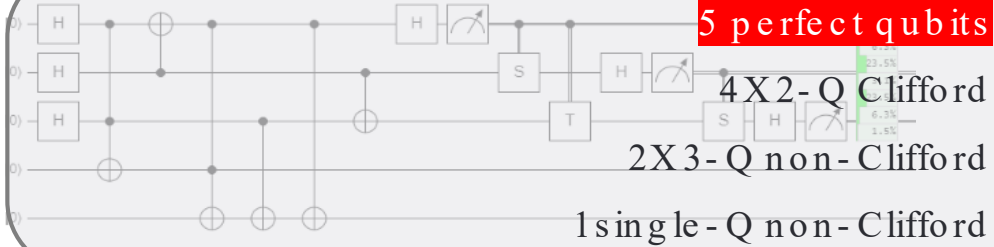

5 perfect qubits

4 X2-Q Clifford

2 X3-Q non-Clifford

1 single-Q non-Clifford

## 2 Surface level

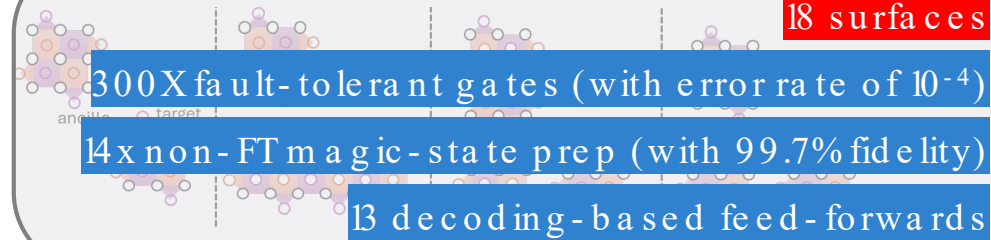

18 surfaces

300 X fault-tolerant gates (with error rate of  $10^{-4}$ )

14 x non-FT magic-state prep (with 99.7% fidelity)

13 decoding-based feed-forwards

## 3 Physical level

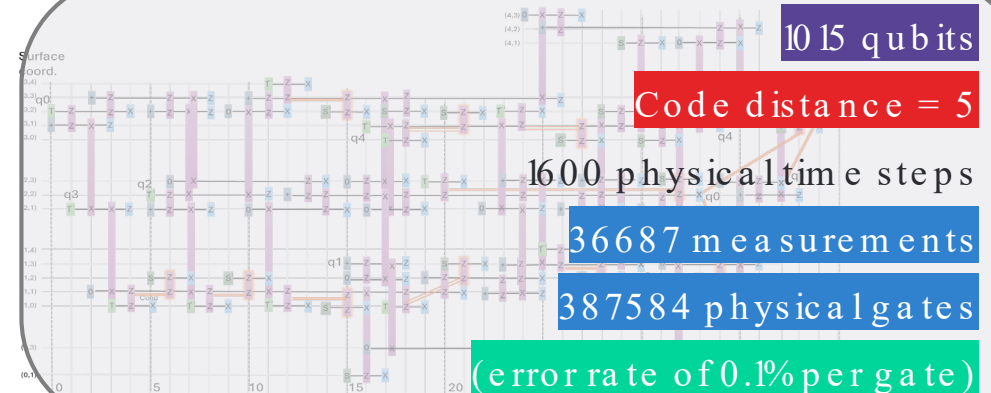

105 qubits

Code distance = 5

1600 physical time steps

36687 measurements

387584 physical gates

(error rate of 0.1% per gate)

High-level controller requirements

Real-time feed-forwards

Non-deterministic protocols

Thousands of control channels

Real-time decoding of thousands of bits

Ultra-high gate fidelity

Extreme phase stability at scale

Fast and easy development



Unrivaled  
Scalability



Cutting-edge  
Analog specs



Classical  
computing  
integration



Ease of use



# Unrivaled Scalability

10<sup>15</sup> Qubits require  
1000-4000 channels!

- ✓ Supports 1000s channels with extremely high density of **26.7 channels/U**
- ✓ Program 1 and NOPX1000s in the exact same way
- ✓ QSync technology supports clock distribution across massive clusters with minimal skew
- ✓ Supports data broadcasting in 100s of nanoseconds across modules

**OPX1000**  
Unrivaled scalability

1,000 channels in  
a single rack





# Unrivaled Scalability

10<sup>15</sup> Qubits require  
1000-4000 channels!

- ✓ Supports 1000s channels with extremely high density of **26.7 channels/U**
- ✓ Program 1 and *N* OPX1000s in the exact same way
- ✓ QSync technology supports clock distribution across massive clusters with minimal skew
- ✓ Supports data broadcasting in 100s of nanoseconds across modules

**OPX1000**  
Unrivaled scalability

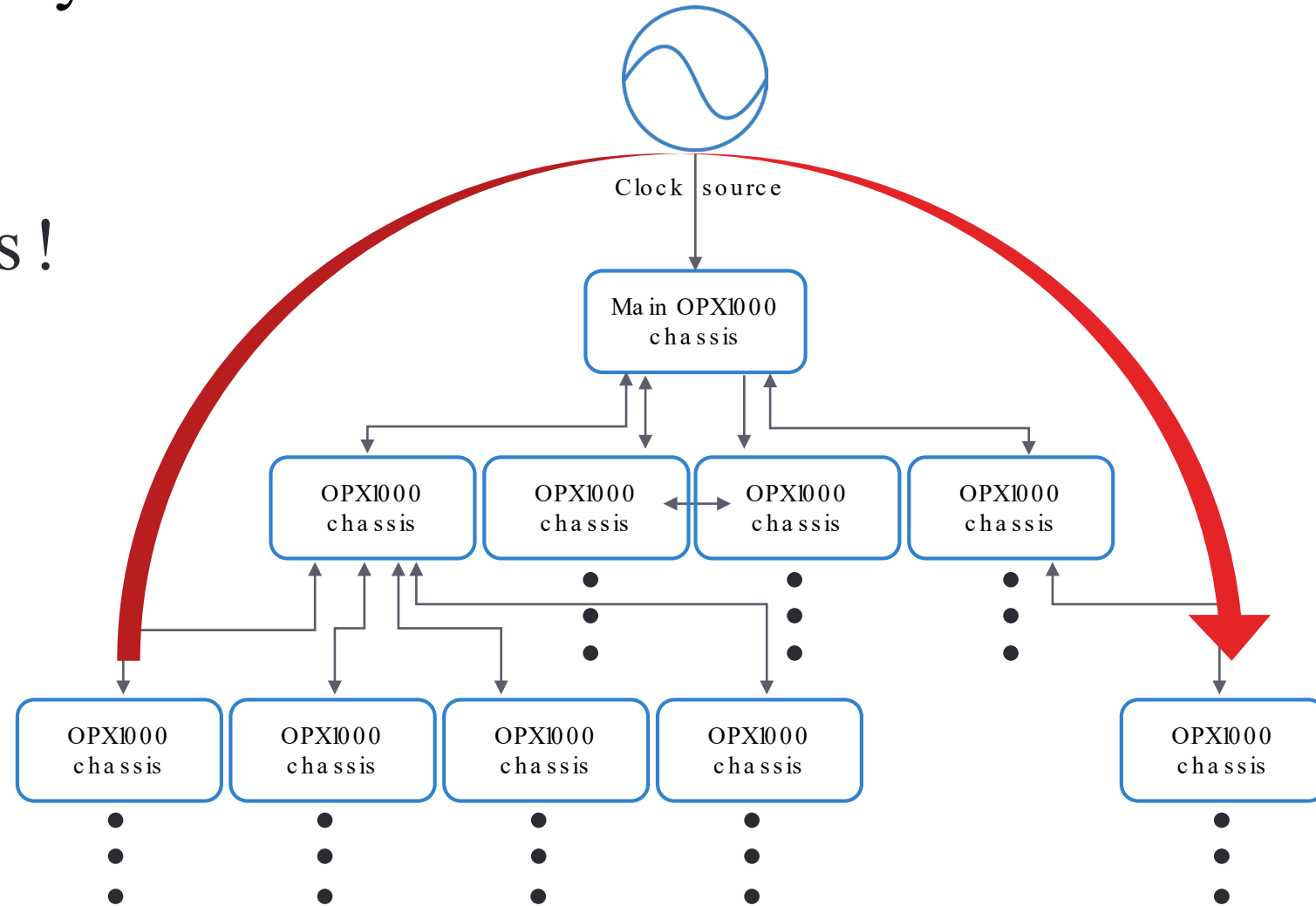



# Deployed large scale systems



ALICE & BOB





# Deployed large scale systems

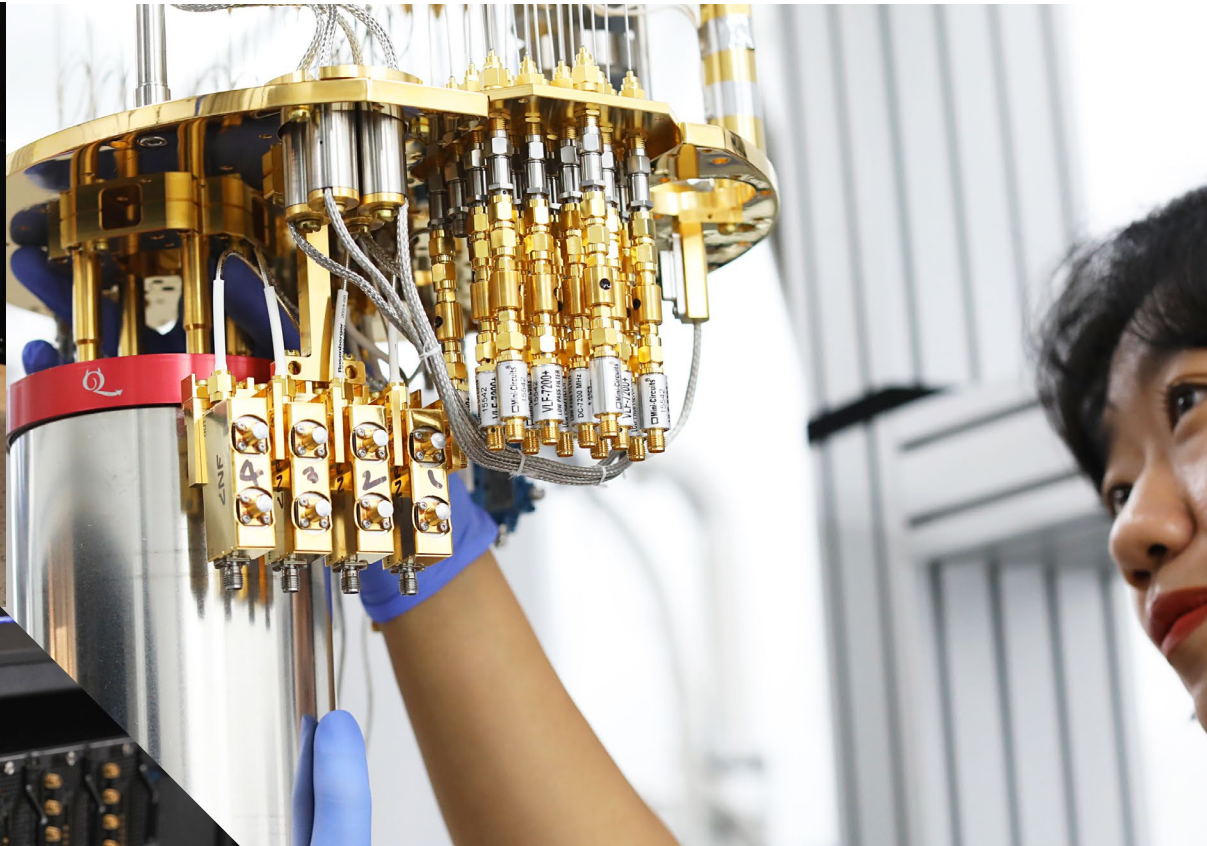

**IQCC** Israeli Quantum Computing Center  
Powered By Quantum Machines





# Phase stability: the need for cutting-edge specs

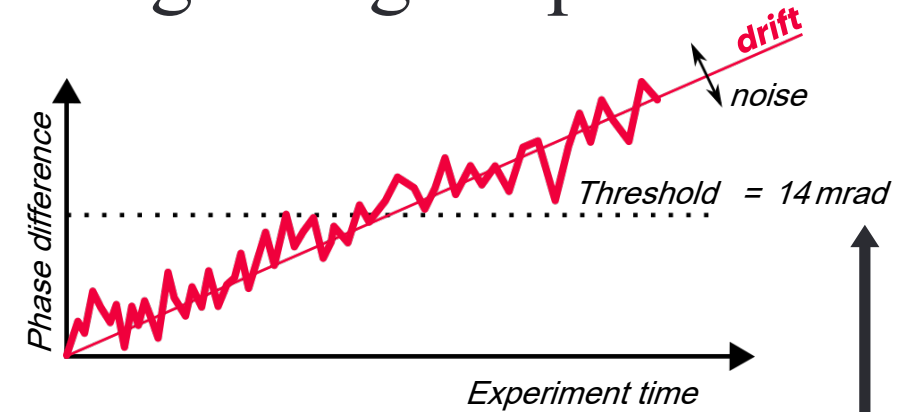
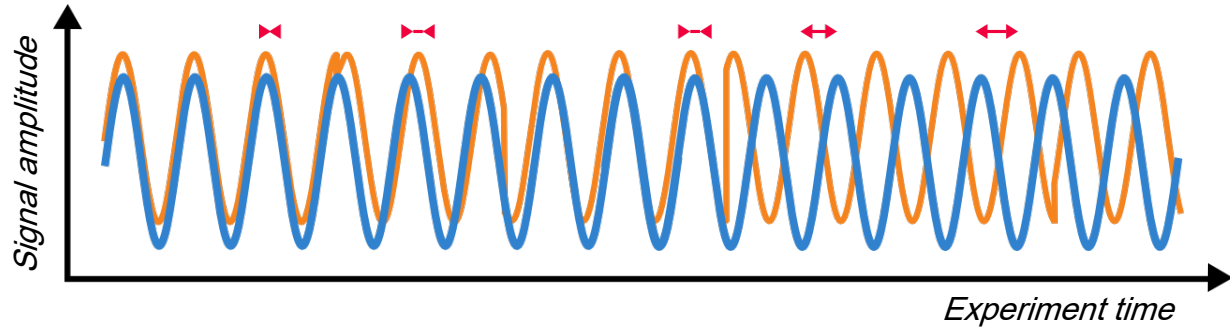

GOAL

Ultra - high gate fidelity: iSWAP gate error less than  $10^{-4}$

Phase stable within 14 mrad

## From phase stability to fidelity

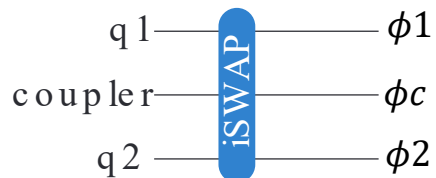

$$\eta = \phi_c - (\phi_1 - \phi_2)$$

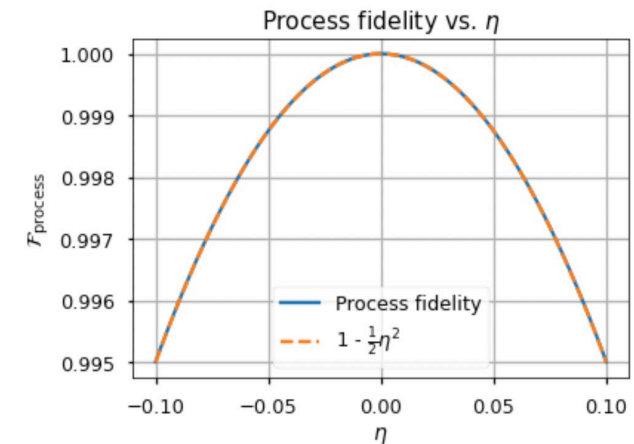

Derivation in: Ganzhorn, Marc, et al. *Physical Review Research* 2.3 (2020): 033447.



# Phase stability: the need for cutting-edge specs

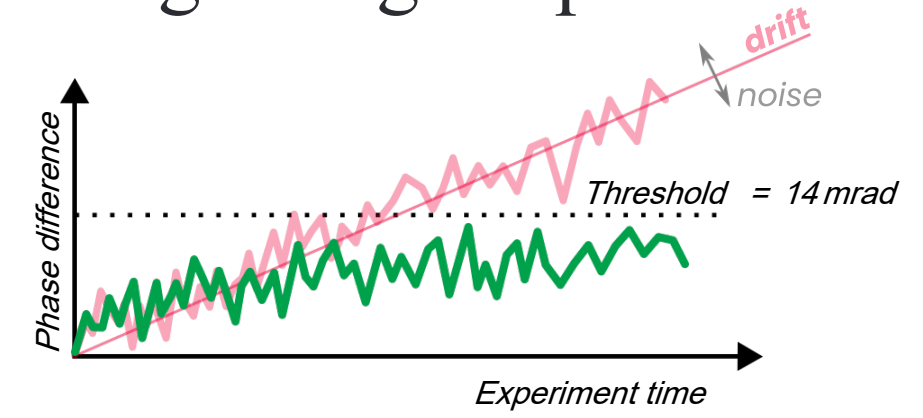
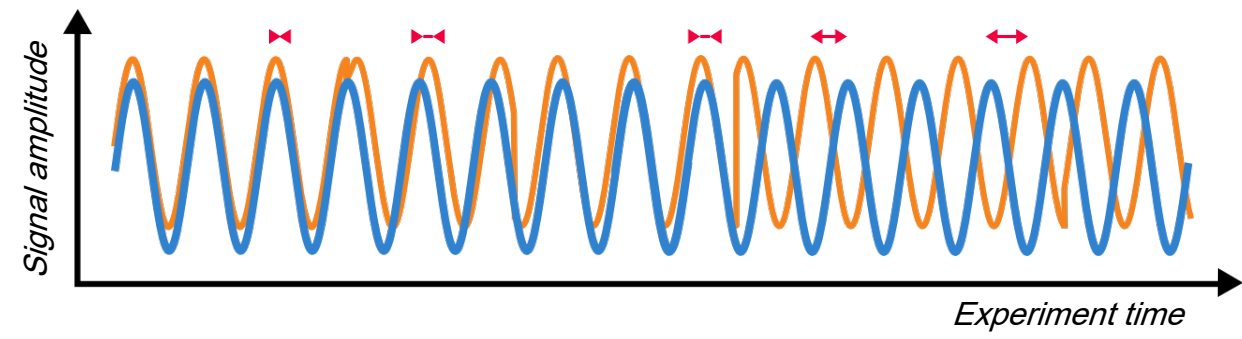

GOAL

Ultra - high gate fidelity: iSWAP gate error less than  $10^{-4}$

Phase stable within 14 mrad

## OPX 1000

Designed for high - fidelity

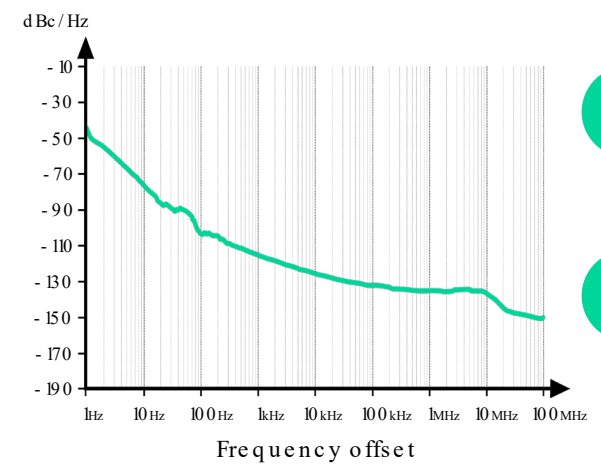

### PHASE NOISE

Less than 5 mrad RMS jitter

### PHASE DRIFT

Less than 6 mrad in 1 hour

allows  $F_{state} > 0.9999$



# Phase stability: the need for cutting-edge specs

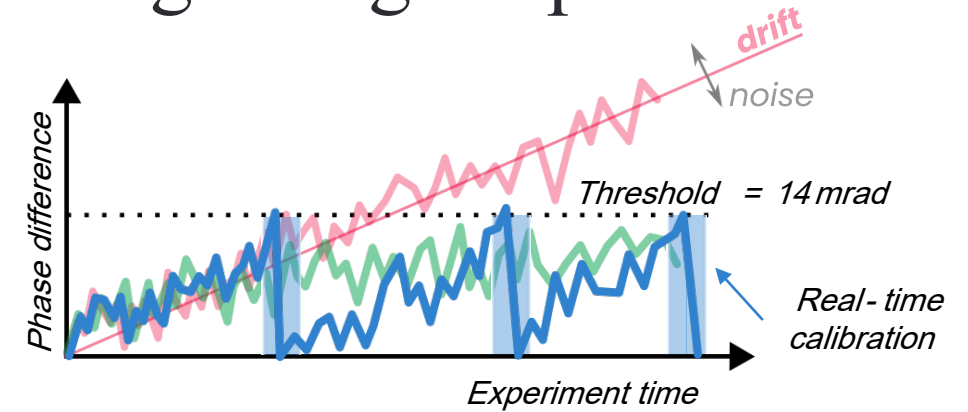
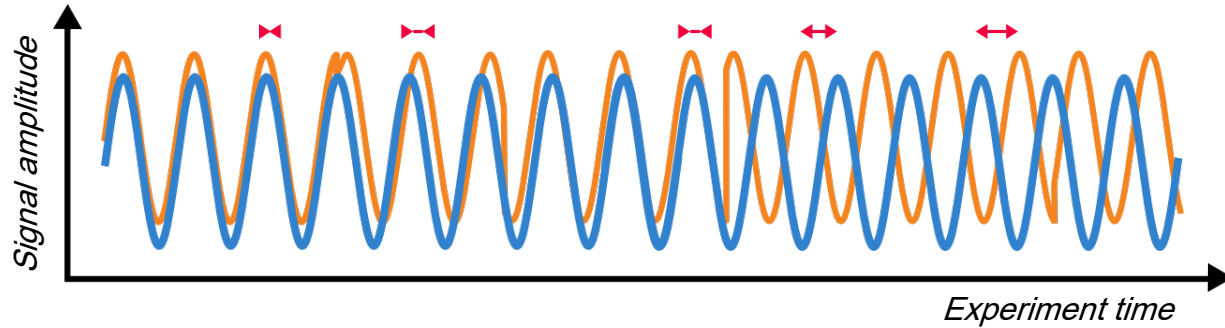

GOAL

Ultra - high gate fidelity: iSWAP gate error less than  $10^{-4}$



Phase stable within 14 mrad

OPX 1000



Real - time Calibrations  
of Circuit Parameters and Phase Reset

In situ embedded calibration

e.g. via Ramsey swap  
- sensitivity higher than iSWAP

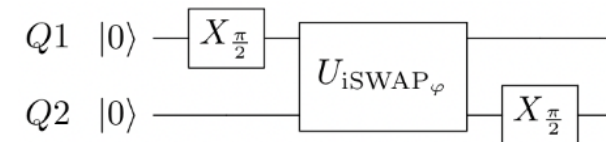



# Phase stability



# RT calibrations



“OPX+ & Octave: Perfect, all - in - one measurement system for SNU’s silicon 5 qubit device!”

Prof. Dohun Kim

✓ Direct - digital synthesis up to 10.5 GHz

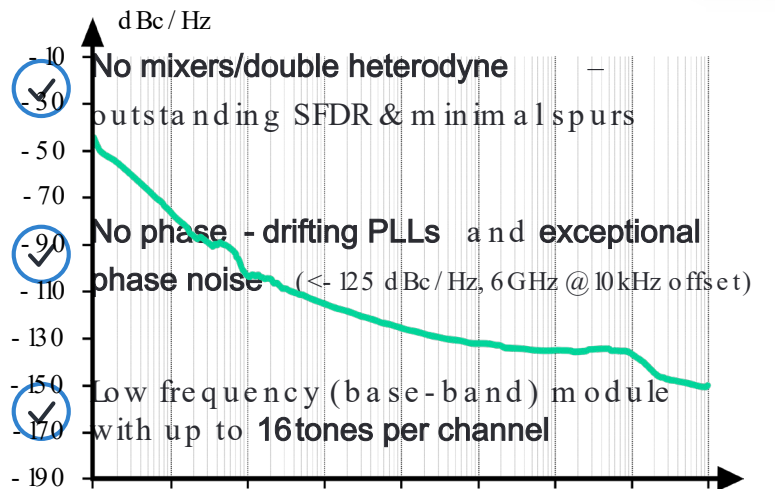

✓ Microwave frequency module with up to 8 tones around 2 carriers per channel

QEC-ready top-notch specs:  
Less than 10 mrad rms jitter  
✓ 2 GSa/s and 4 GSa/s modes  $F_{state} > 0.9999$  allows

Cutting - edge analog specs

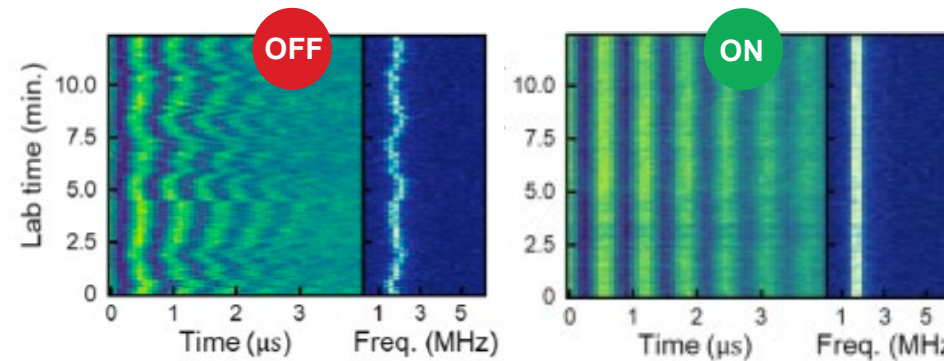

Park J. et al, arXiv:2403.02666 (2024)

Unparalleled classical computing integration



# Cross - resonance gate calibration

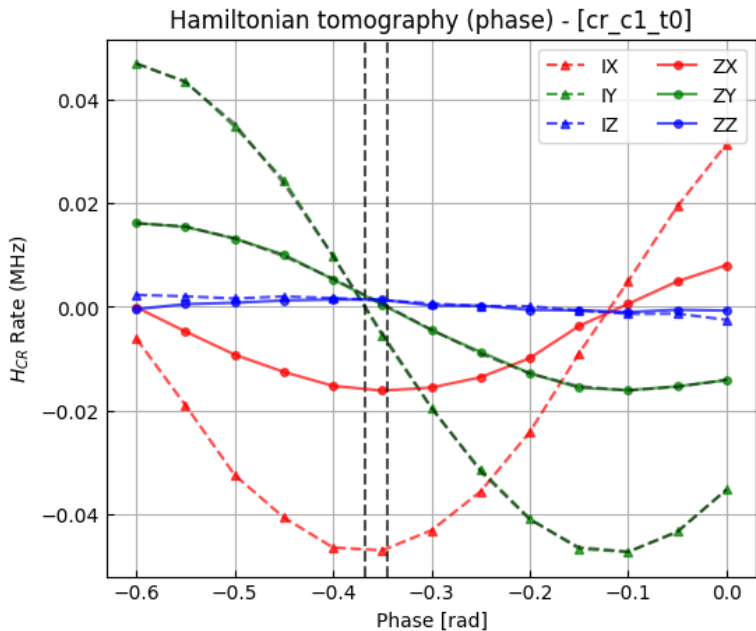

*Phase calibration of correction gate for cross - resonance gates, enabled by OPX*

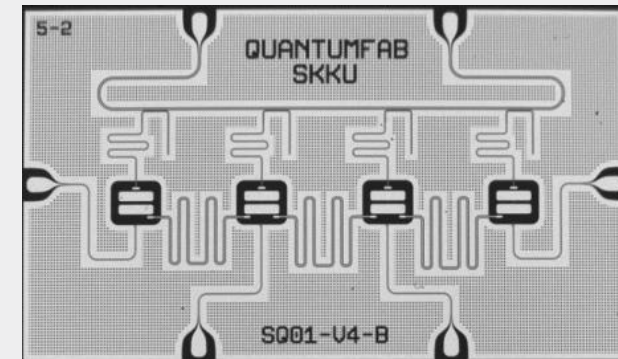
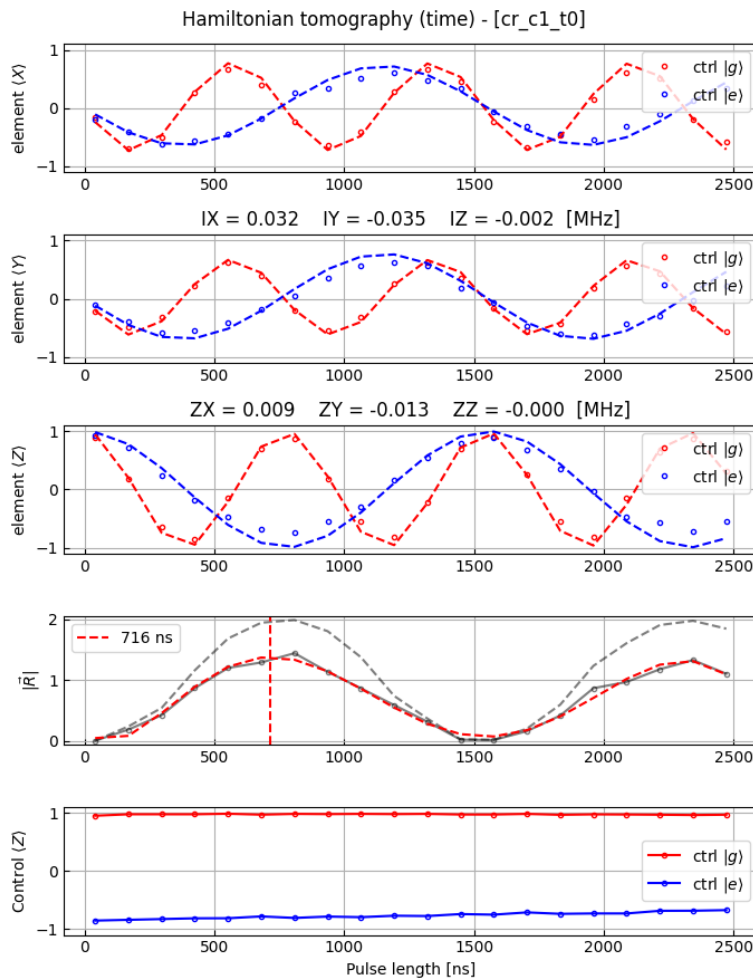

Courtesy of:

**Prof. Yonuk Chong**  
 Professor and Director of Qcenter,  
 Sung Kyun Kwan University



성균관대학교  
 SUNG KYUN KWAN UNIVERSITY



**Fast and precise  
 cross - resonance  
 calibration**



SUNG KYUN KWAN UNIVERSITY(SKKU)





# Performing FT surface-level circuits

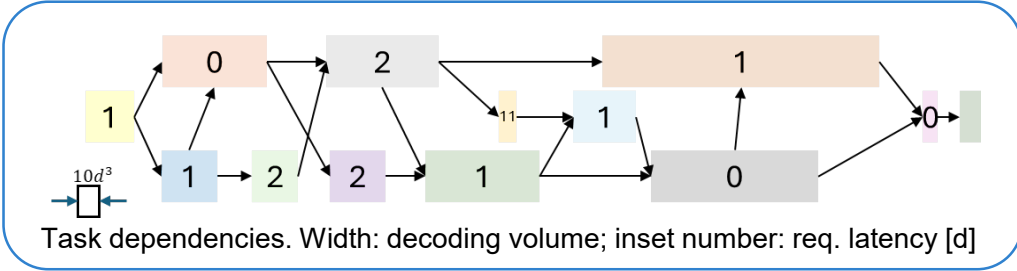

**Using repeat-until-success for T state prep**

Run magic state prep circuit but discard the result and “start-over” based on real-time measurements

Increased fidelities from 98% to 99.7%

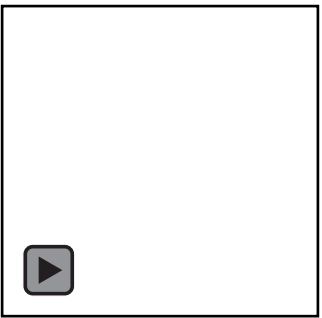
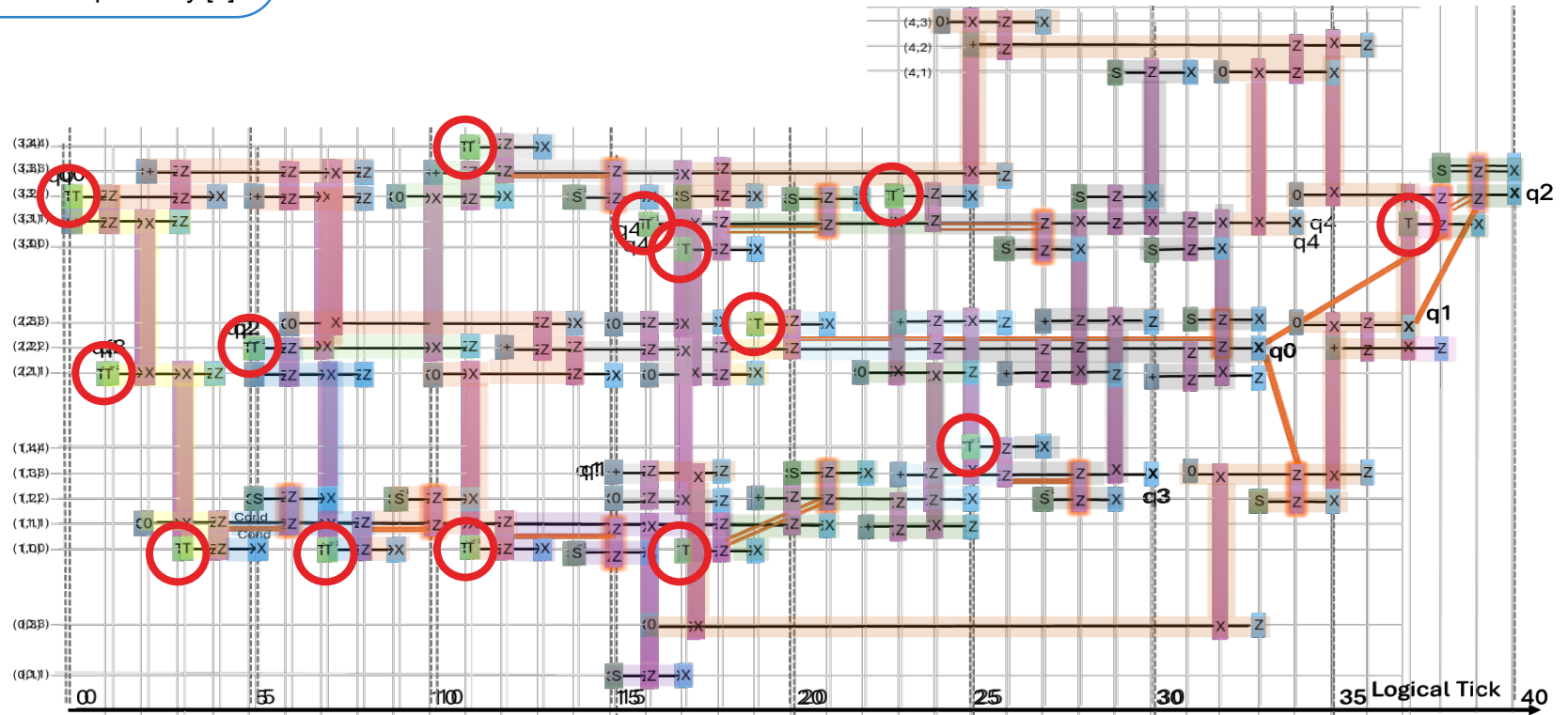



# Physical-level gates and measurement

36687 total measurements

387584 physical gates

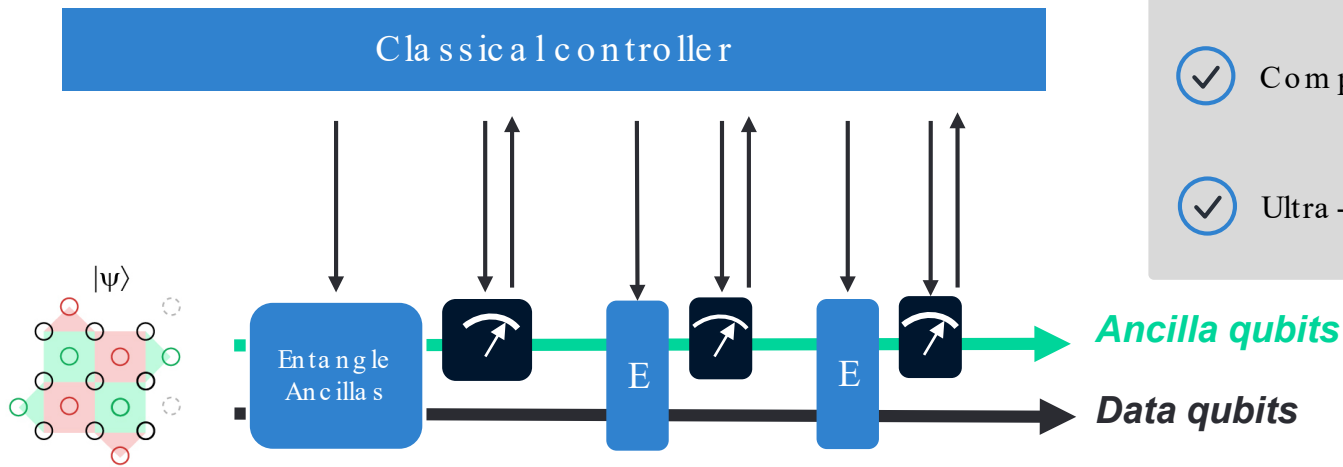
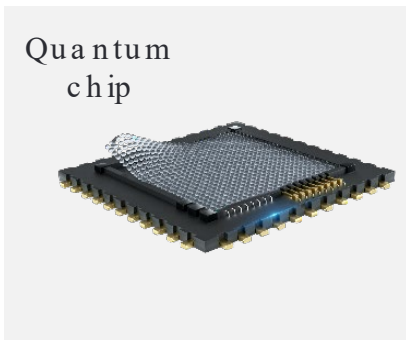
14X non-FT magic-state preparation (99.7%)



## Processor - based controller

- ✓ Unmatched real-time compute power
- ✓ Fully parametric real-time signal generation
- ✓ Comprehensive control-flow
- ✓ Ultra-fast feedback: **active reset < 120 ns**

# FT surface-level gates

300X fault-tolerant gates ( $10^{-4}$ )

13 decoding-based feed-forward gates

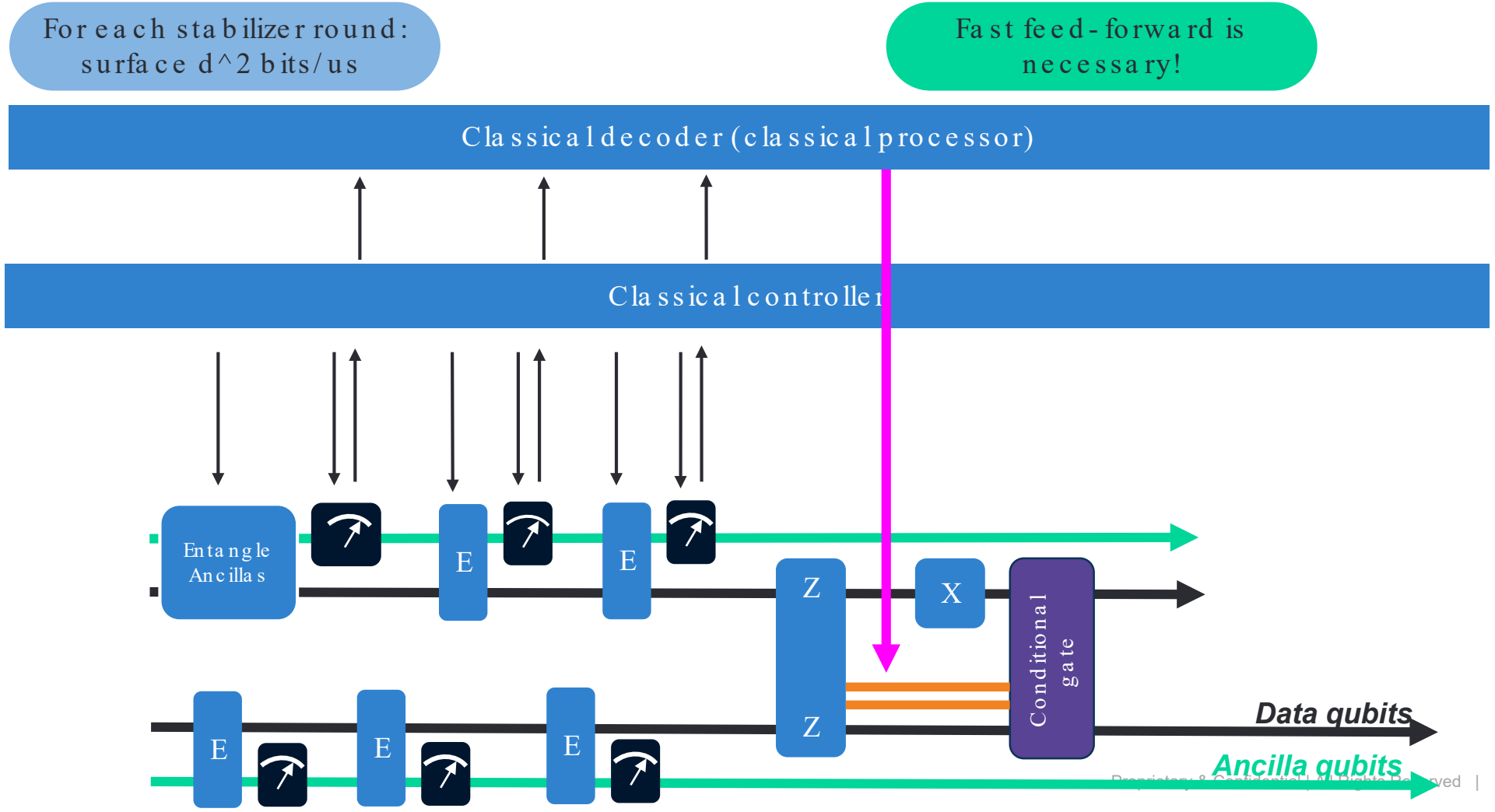
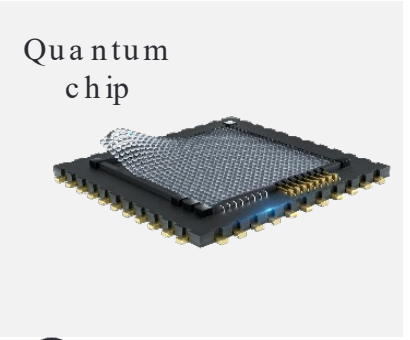

# QEC processing and control flow requirements

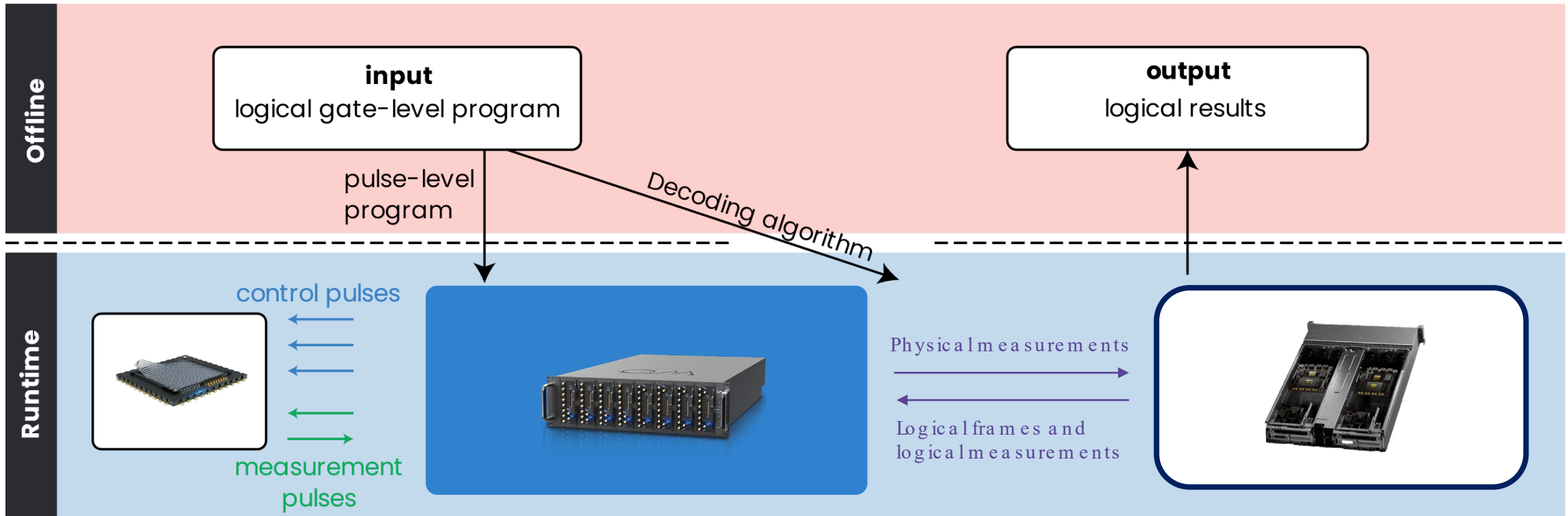

# QEC processing and control flow requirements

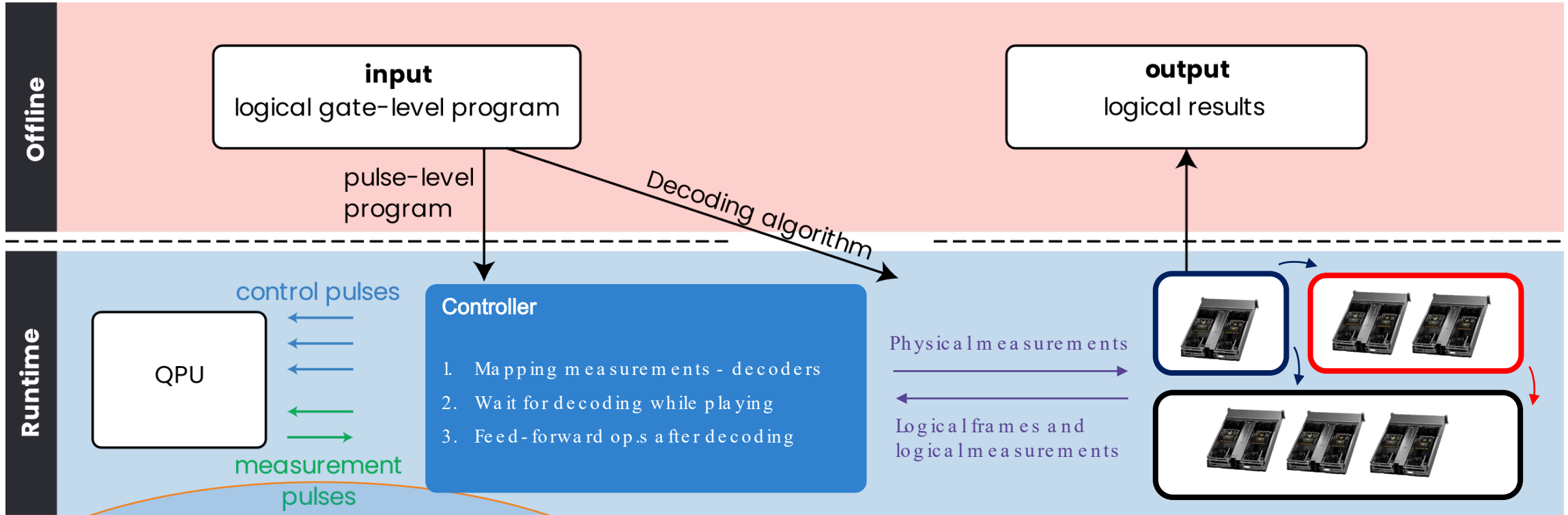

Ultra - low latency QPU- controller (100s ns)

Full control flow in controller and decoder

Parallelize decoders

QPU- Decoder roundtrip <10 us

High performing decoders

Low- latency communication



# Algorithmic initialization for hot spin qubits

As qubit arrays scale, higher temperatures are required to get sufficient cooling power.

Dirac's OPX-enabled algorithmic qubit initialization bring SiMOS spin qubits above 1K into the realm of fault-tolerance.

**Ease of programming**  
even for repeat-until-success loops 

## Real-time corrections and loops

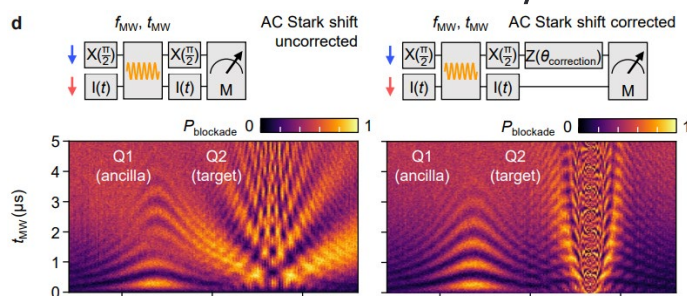

1q and 2q RB made simple

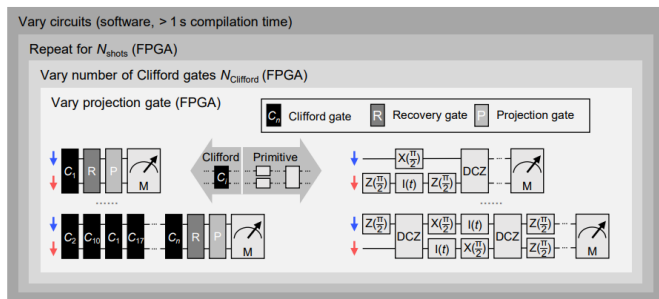

Drive signals generated parametrically



 **Real-time decision making**  
based on readout, with ultra-low latency

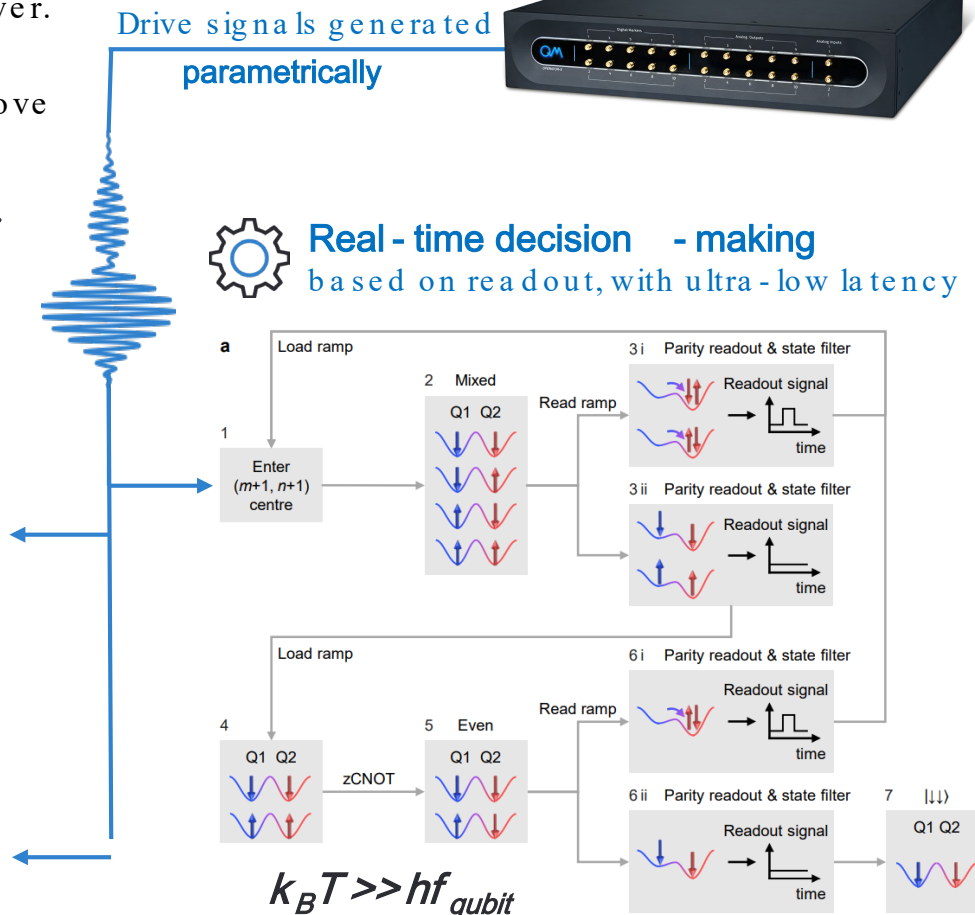

$$k_B T \gg hf_{qubit}$$



“Dirac is delighted to partner with Quantum Machines, and credits their OPX control system, with its real-time capabilities, as instrumental in achieving the results outlined in our research. The ease of programming sequences in QUA significantly streamlined the experimental process.”

**Prof. Andrew Dzurak**

Scientia Professor in Quantum Engineering,

University of New South Wales

CEO, Dirac



Source: Huang, J.Y., Su, R.Y., Lim, W.H. et al. [High-fidelity spin qubit operation and algorithmic initialization above 1 K. Nature, 627, 772 \(2024\)](#)

# QEC processing and control flow requirements

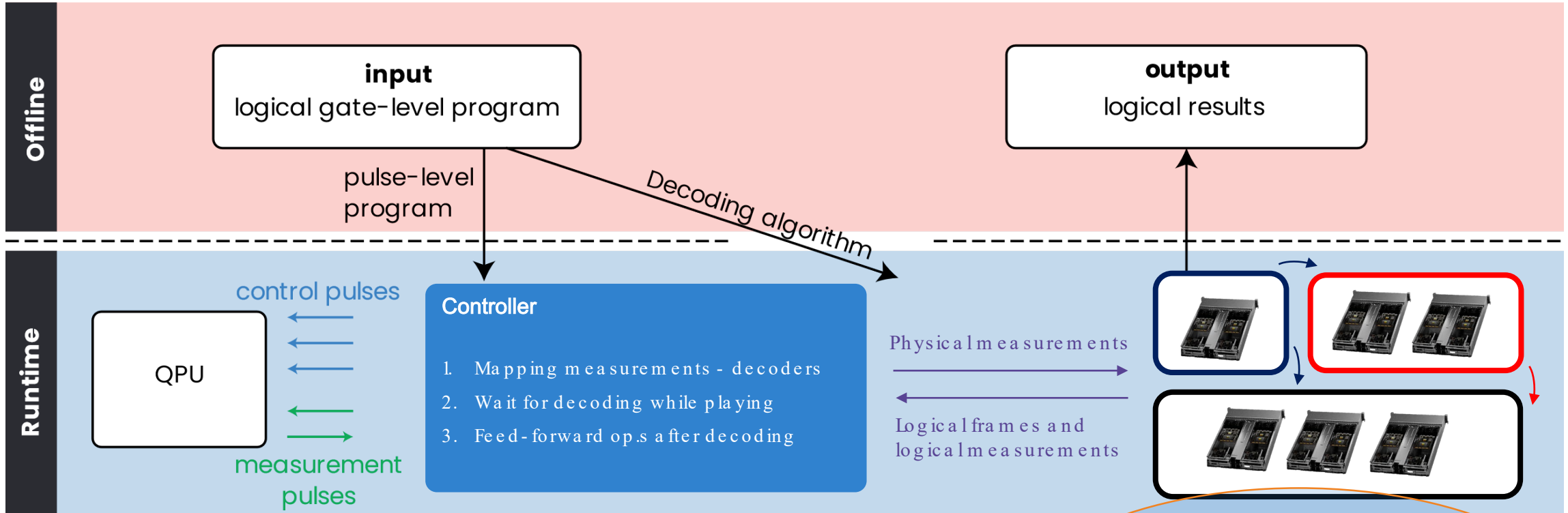

Ultra - low latency QPU- controller (100s ns)

Full control flow in controller and decoder

Parallelize decoders

**QPU- Decoder roundtrip <10 us**

High performing decoders	Low- latency communication
--------------------------	----------------------------

# DGX- Quantum to fulfill QEC requirements

- ❖ Allows the controller and the CPU/GPU to deliver unprecedented performance in quantum-classical processing with an **ultra - low latency interface QPU - GPU/CPU of less than 4  $\mu$ s**
- ❖ Allows for real-time decoders to be programmed in SW, yet achieve best HW performance at scale
- ❖ Allows the decoder to determine the control flow
- ❖ Supports any decoder algorithm and QEC code

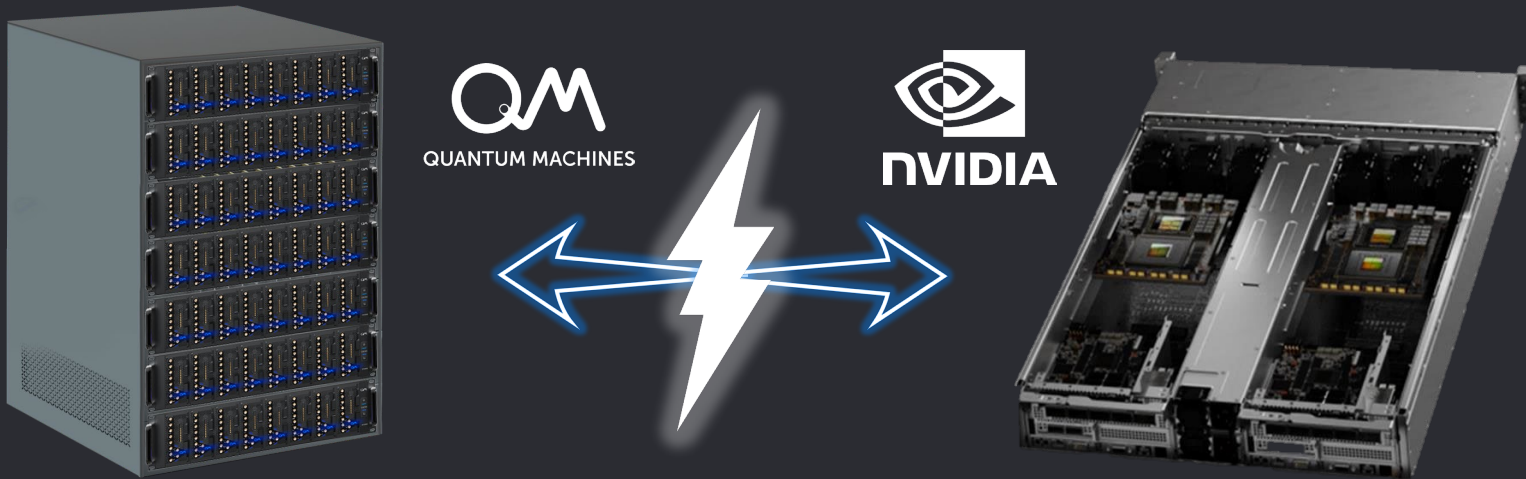

# DGX- Quantum to fulfill QEC requirements

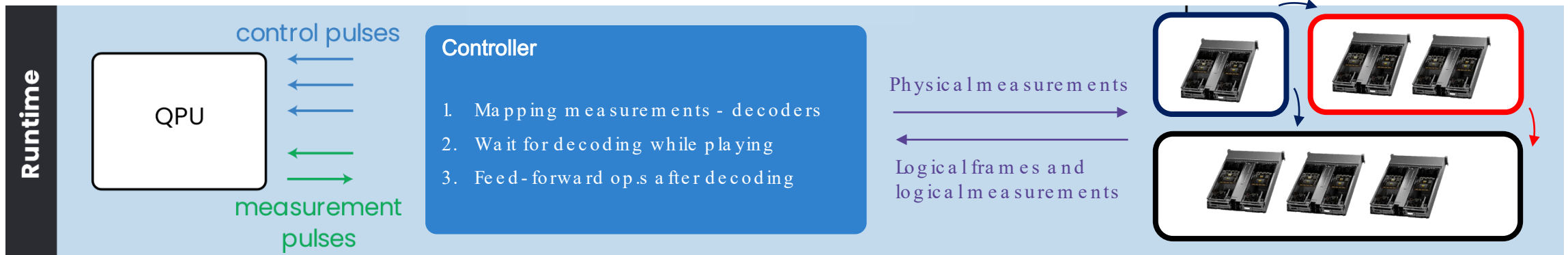



# Ease of use and flexible programming

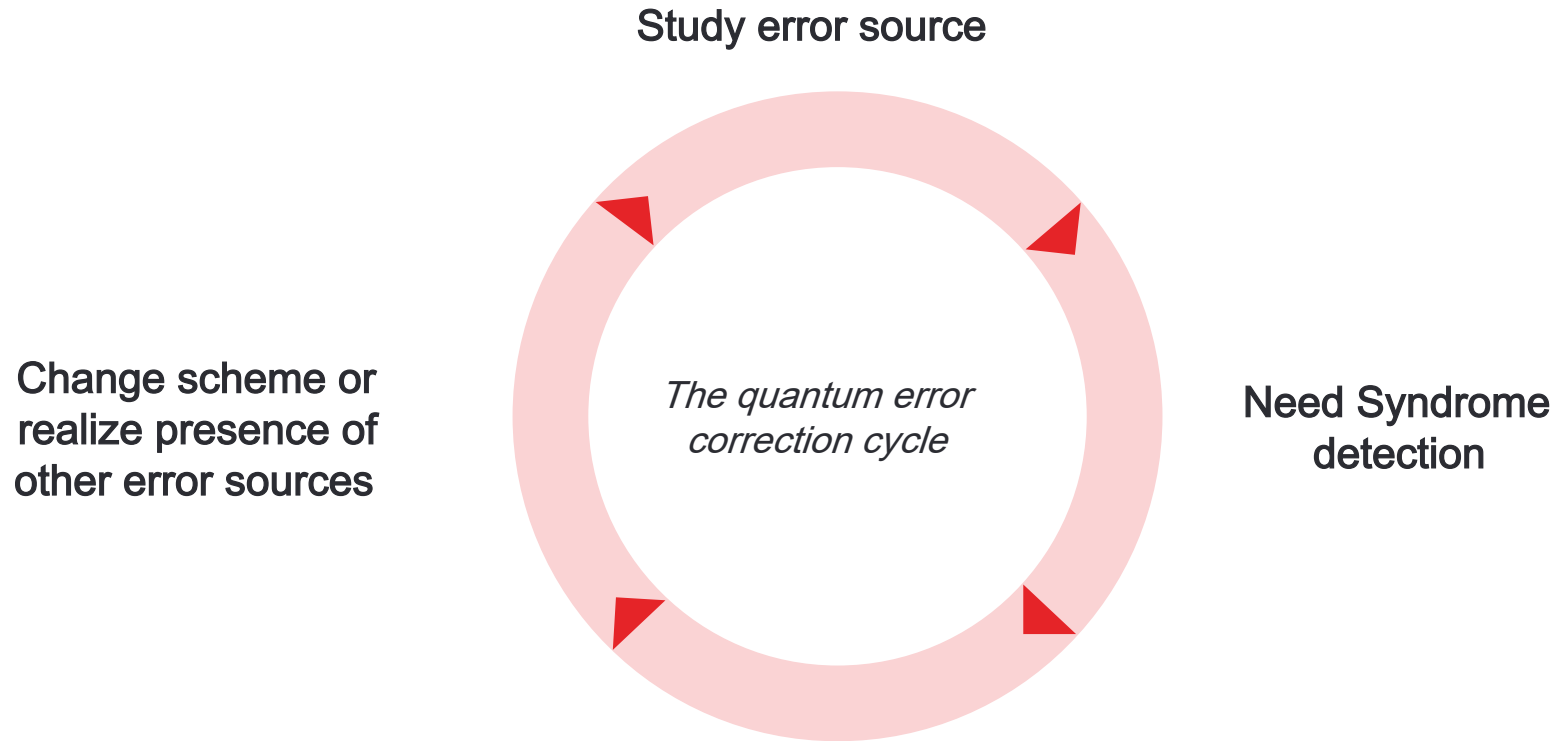

Low level (FPGA): ~6 months



Implement Decoder



High level (QUA/CUDA): ~6 weeks

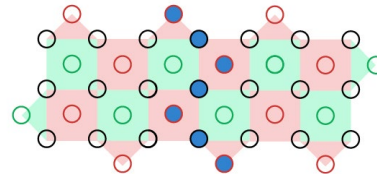



# Real-time Bayesian estimation and two-axis control of spins

Each new single shot outcome is used to update and narrow down the estimated probability distribution via real-time Bayesian estimation.

Then, continuous surveillance of fluctuating fields is used for qubit control

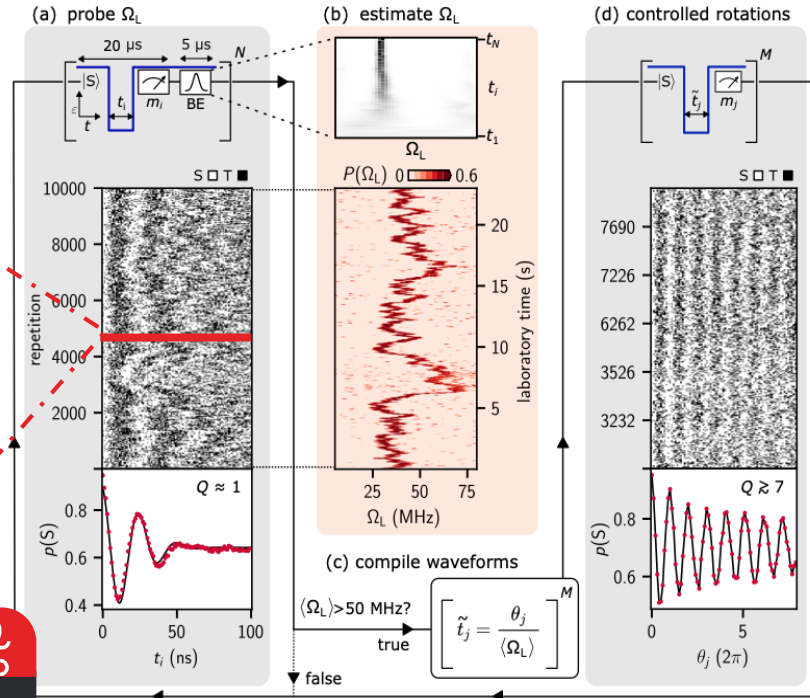
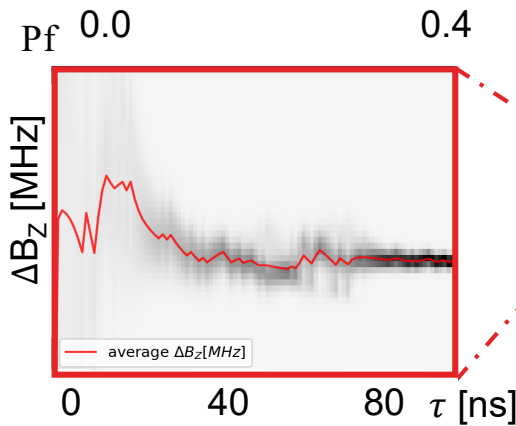
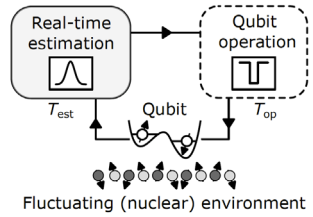

“The OPX’s fast feedback and unique real-time processing capabilities were critical for our experiment.

Combining these with the OPX’s **intuitive programming** and QM’s state-of-the-art cryogenic electronics allowed us to do something that we have dreamt of doing for years.”

**Prof. Ferdinand Kuemmeth**  
Center for Quantum Devices,  
Niels Bohr Institute,  
University of Copenhagen, Denmark



## QUA CODE

```
measure("meas_pulse", "RF-QPC", None, demod.full("integW1", I))
assign(state[i-1], I > 0)
assign(ri, Cast.to_fixed(state[i-1])-0.5)

with for_(fB, fB_min, fB < fB_max, fB + dfB):
    assign(C, Mat.cos2pi(Cast.mul_fixed_by_int(fB, t_samp * i)))
    assign(Pf[index], (0.5 + ri *(alpha + beta * C)) * Pf[ind1])
    assign(index, index + 1)

assign(norm, 1 / Mat.sum(Pf))
with for_(index, 0, index < Pf.length(), index + 1):
    assign(Pf[index], Pf[index] * norm)
```

Sources: Berritta, F., et al. [Real-time two-axis control of a spin qubit. Nat Commun 15, 1676 \(2024\)](#)

Berritta, F., et al. [Physics-informed tracking of qubit fluctuations. arXiv preprint arXiv:2404.09212 \(2024\).](#)

$$P(m_i|\Omega) = \frac{1}{2} [1 + r_i (\alpha + \beta \cos(2\pi\Omega t_i))]$$



## of - use

V modules as needed

ke programming

orkflows for ultra - fast  
l - time retuning

B in 48 hours from

its with any to -  
exceptional  
tion, and no

annels with extremely  
7 channels/U

e GPU - quantum HW  
rip delay < 4  $\mu$ s

## scalability

# OPX1000



# WHY?

## Processor -

- ✓ Unmatched control-flow
- ✓ Ultra-fast feedback
- ✓ Enables the execution of complex sequences just

- ✓ Direct Synthesis up to 10.5 GHz

- ✓ Outstanding performance can be achieved with a single heterodyne channel

- ✓ Baseband multiplexed with 8 tones

- ✓ 2 GSa/s and 4

## Cutting analysis

# Factoring 21 in QEC: can we do it?

## Ease-of-use

- ✓ Modular: Mix LF/MW modules as needed
- ✓ Intuitive pseudo-like programming
- ✓ Out-of-the-box workflows for ultra-fast calibration and real-time retuning
- ✓ Simple to set up: **RB in 48 hours** from unboxing is typical

- ✓ Effortlessly add units with any topology, data-sharing, exceptional phase synchronization, and no software redesign
- ✓ Supports 1000s channels with extremely high density of **26.7 channels/U**
- ✓ **NVIDIA - QM**: Native GPU-quantum HW integration, **roundtrip delay < 4 μs**

## Unrivaled scalability

## Processor - based controller

- ✓ Unmatched real-time compute and control-flow
- ✓ Ultra-fast feedback: **active reset < 120 ns**
- ✓ Enables the most advanced dynamic sequences just out of the box

# OPX1000

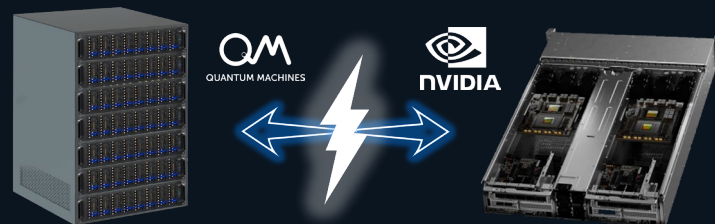

- ✓ Direct Synthesis (DDS) technology up to 10.5 GHz
- ✓ Outstanding purity and SFDR (cannot be achieved with mixers/double heterodyne calibration)
- ✓ Baseband module with up to 16 multiplexed tones & Microwave module with **8 tones 2 carriers per channel**
- ✓ 2 GSa/s and 4 GSa/s modes

## Cutting - edge analog specs

# Yes, we can!

## Ready?

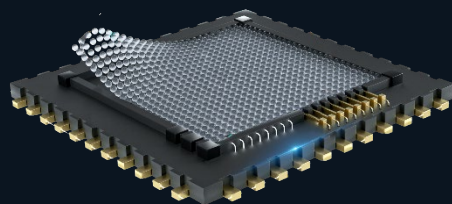
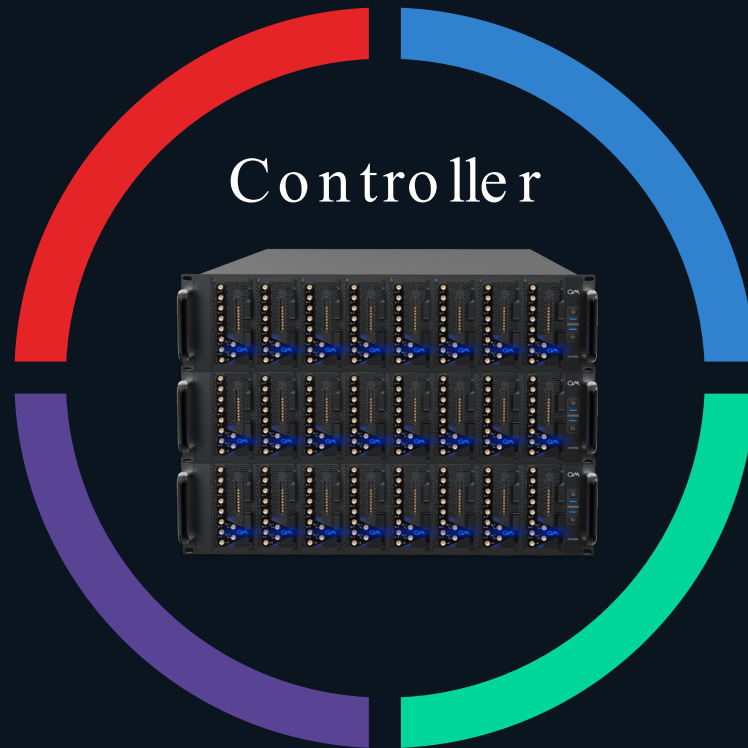

QPU

$$21 = 3 \cdot 7$$

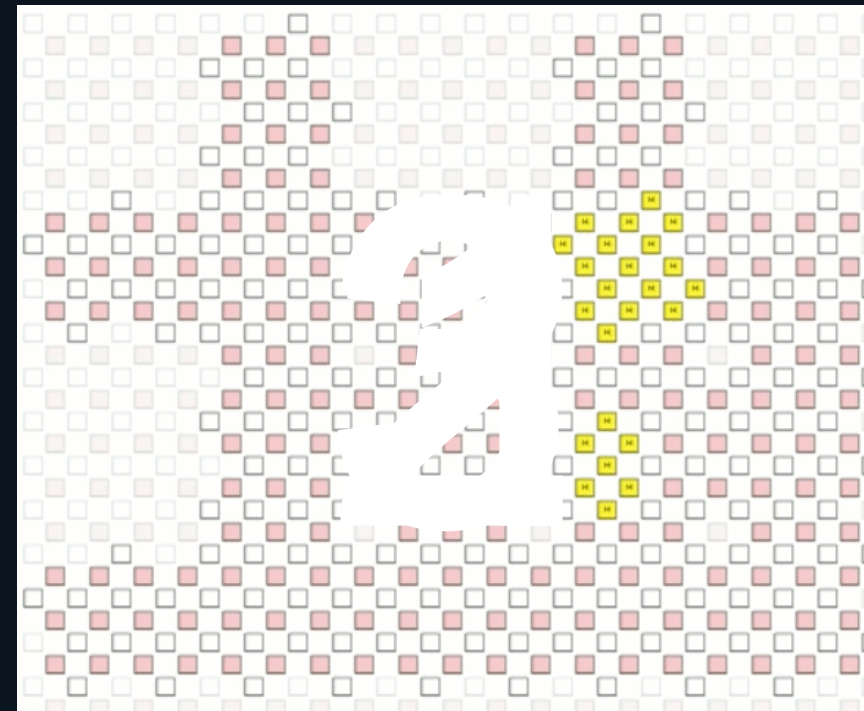

# Thank you

16 큐비트 캘리브레이션 및 양자  
텔레포테이션의 라이브 데모를 보러 오세요.