

Advancing Quantum Technologies With Keysight

Gabriel Lenetsky
Business Development, Quantum

Who is Keysight?

Manufacturing, Supply Chain, & Support at Scale

Incorporated in Korea for 40 years
190+ employees in the country



World's First 1000 Qubit
Commercial Control System



Started Silicon Valley



Interdisciplinary team of scientists,
engineers, & software developers

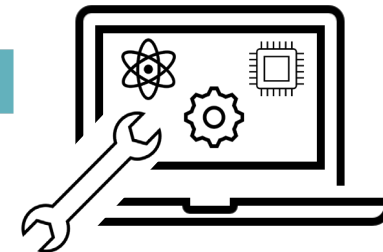

Keysight's Differentiated End-to-End Portfolio for Quantum

QuantumPro

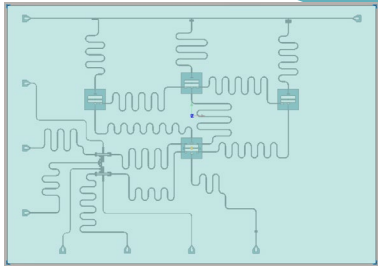

Quantum Computing SW



Quantum Control System (QCS)

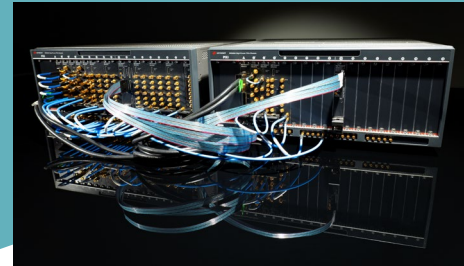

Test & Measurement



Engage globally with hundreds of companies, universities, and research institutions

Provide in state-of-the-art T&M solutions for cryogenic applications

Form strategic partnerships with the industry, research, and government consortiums

Expand our leadership by providing the next generation of solutions for quantum



The Future of Quantum Computing

Acknowledging Its Foundations Were Laid in the Past



What is next for quantum computing?

Quantum Collaboration Agreement between AIST & Keysight

Mission: Build a 1000 Qubit System, Next Generation Control, Quantum Error Correction, Cryogenic Systems Engineering



1000
Qubit



Keysight's Dr. Eric Holland and AIST's Norimitsu Murayama signed the agreement to collaborate on quantum research

Advance Collaborations with Keysight Quantum Cloud Solutions

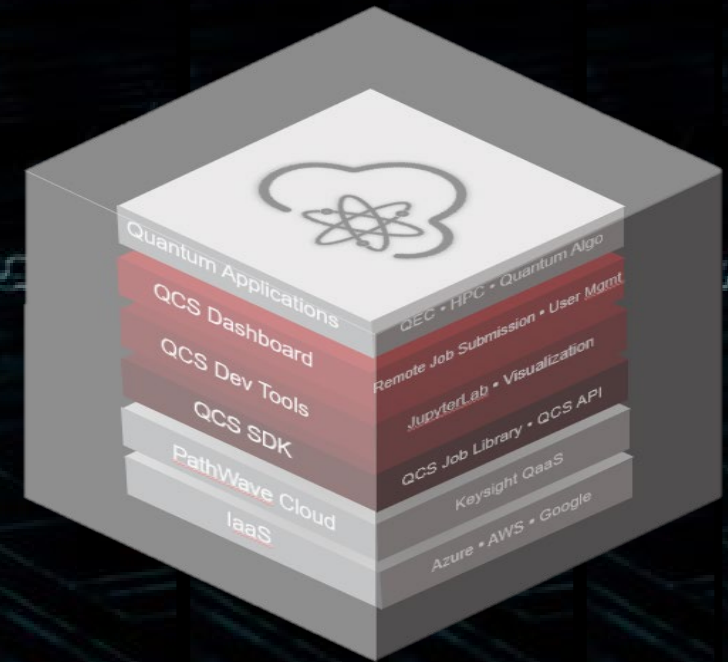

Full-stack Cloud Solution

- Comprehensive cloud-hosted platform suite for running quantum programs at scale.
- Interactive development environment.
- Scientific Visualization and Experiment Workflows.

Keysight Chosen to Enter Riken Quantum Computing Ecosystem

64 Qubit Superconducting Quantum Processor



Cryogenic Component Characterization

Keysight – Bluefors Collaboration

Challenge:

- Room temperature characterization of components is insufficient to predict performance at cryogenic temperatures
- *In-situ* cryogenic calibration method required to isolate individual DUTs from the cryostat wiring

Solution:

- Cryogenic calibration standards allows to move reference plane down to switch at mixing chamber
- 1-port Short-Open-Load S-parameter measurements using Keysight PNA-X Network Analyzer

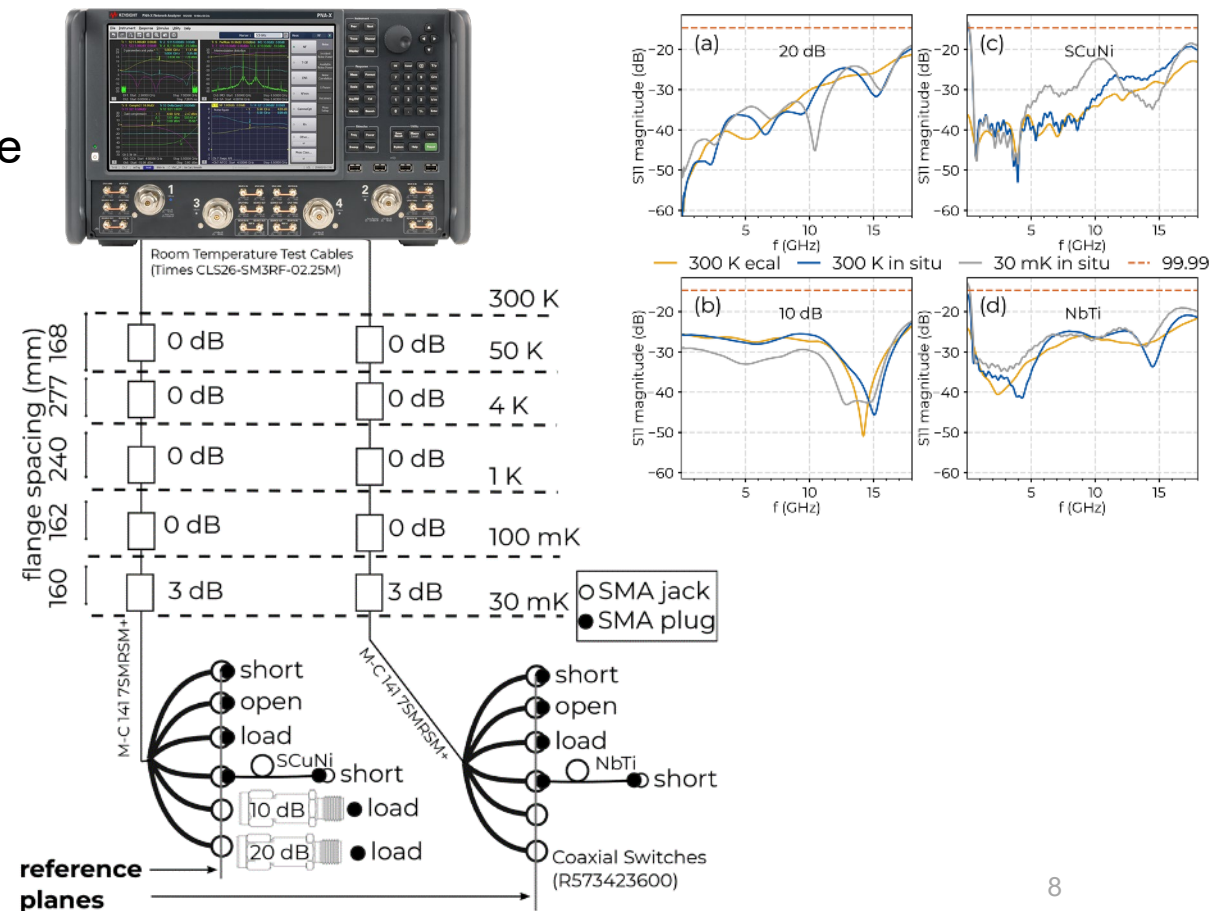

What Are the New Solutions From Keysight?

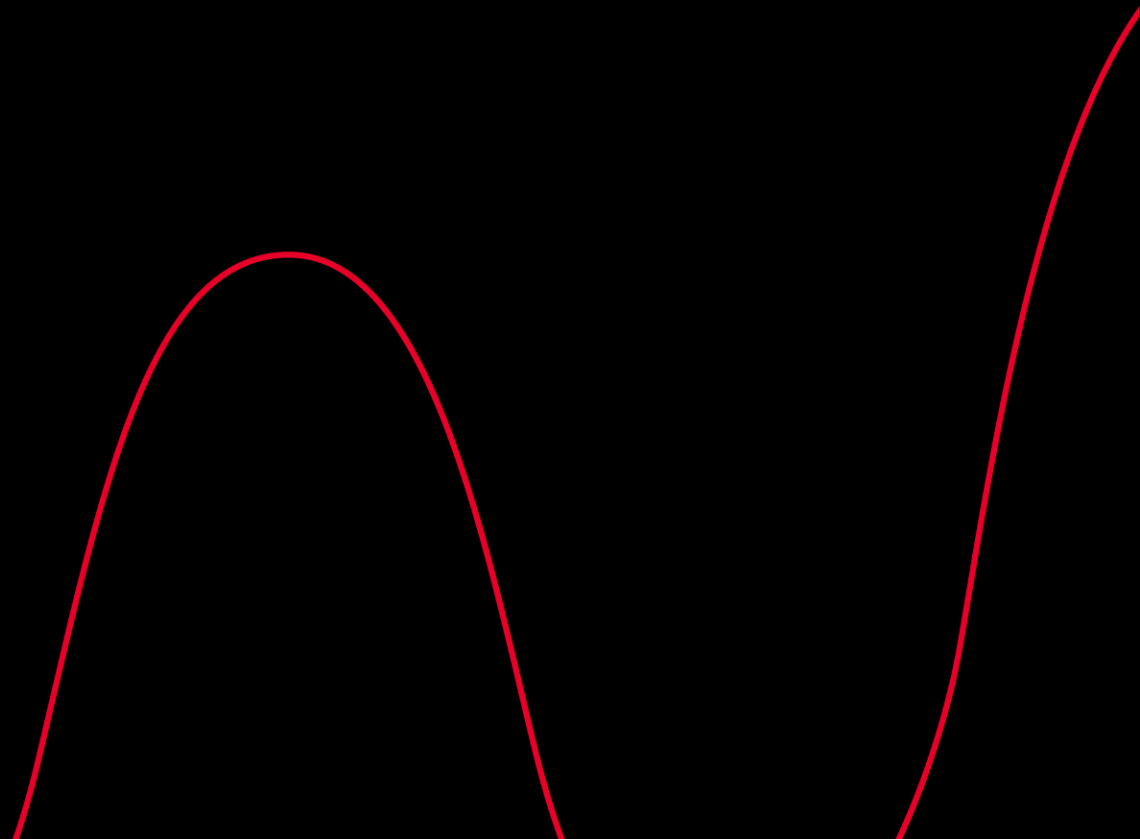

New Testing Capabilities to Strengthen Post-Quantum Cryptography

Keysight Inspector: New Solution Offering Based on Recent Riscure Acquisition

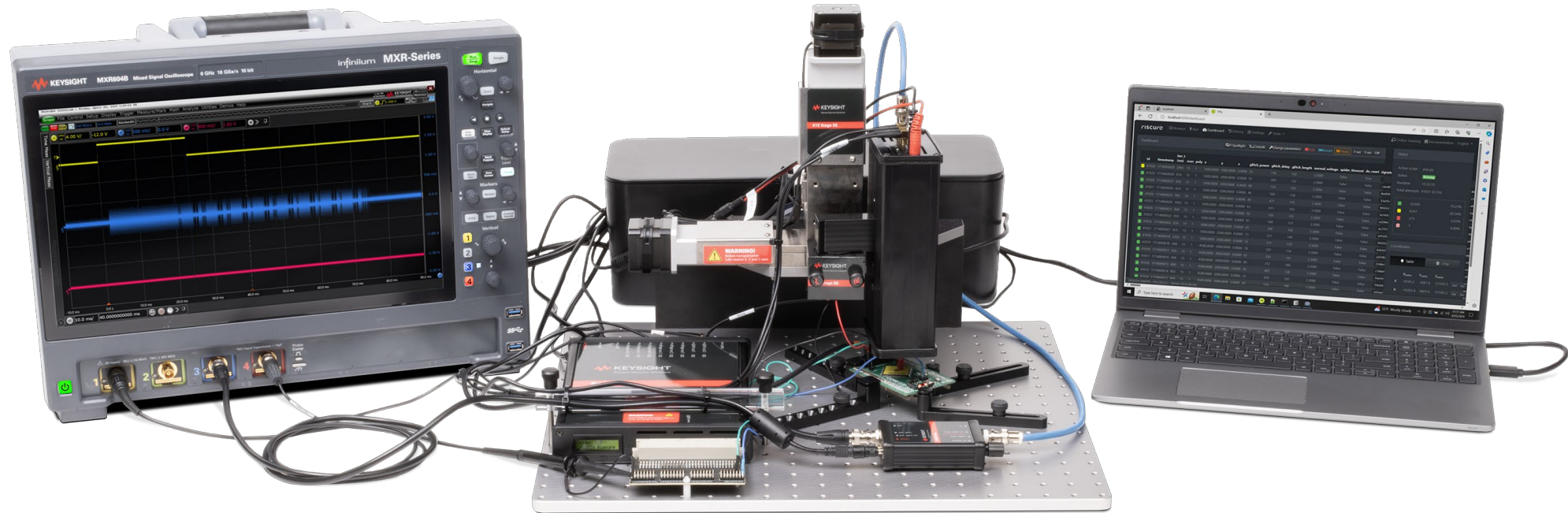

- Verify that products are secure with PQC encryption algorithms
- Government institutions and security test labs can verify the strength of 3rd party products.

Workflow for Superconducting Qubits in QuantumPro Update 2.0

Faster Design Cycle for Quantum Chips with An Integrated Circuit/Layout/EM/Quantum Solution

quantum parameters

Extracted Parameters								
	Q1	Q2	Q3	Q4	R1	R2	R3	R4
L	11.5 nH	11 nH	10.5 nH	10 nH				
Freq	5.95 GHz	6.1 GHz	6.3 GHz	6.44 GHz	8.65 GHz	8.92 GHz	9.41 GHz	9.67 GHz
Q1	311 MHz					1.22 MHz		0.865 MHz
Q2		313 MHz			1.49 MHz			1.01 MHz
Q3			319 MHz			1.62 MHz	1.21 MHz	
Q4				317 MHz	2.12 MHz		1.27 MHz	
R1		1.49 MHz		2.12 MHz	10.6 kHz			
R2	1.22 MHz		1.62 MHz			6.48 kHz		
R3			1.21 MHz	1.27 MHz			4.84 kHz	
R4	0.865 MHz	1.01 MHz						2.83 kHz

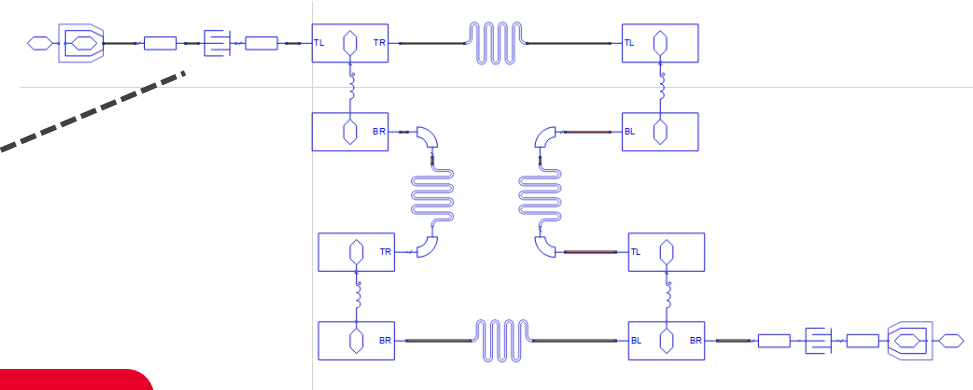

Qubits Circuit

Quantum Parameters

Qubits Layout

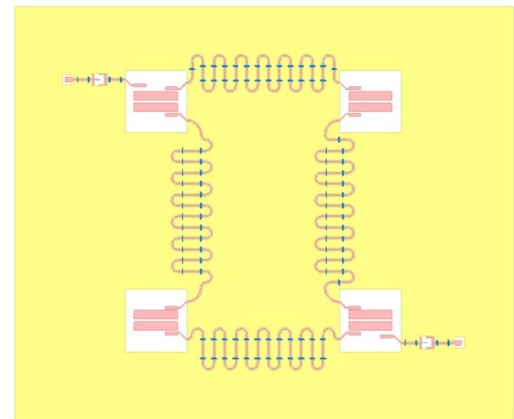

MoM,
FEM

EM Solution

EM Setup

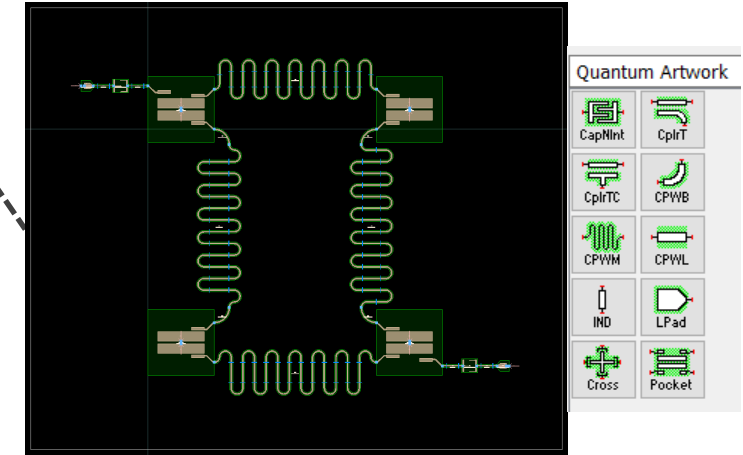

Simulation on HPC environments



Addition of Josephson Traveling Wave Parametric Amplifiers

DV-Quantum Key Distribution Test Bed

Photonic Hardware and Software

Modular Python Design

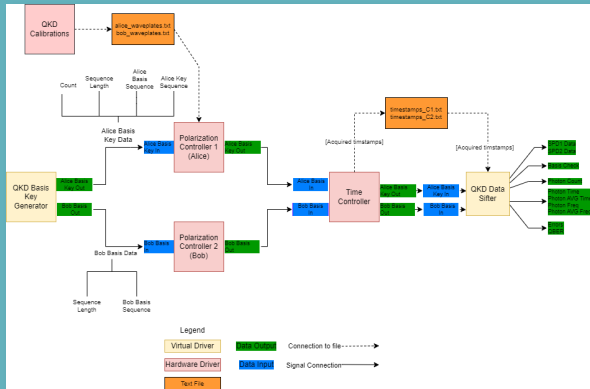

Labber GUI

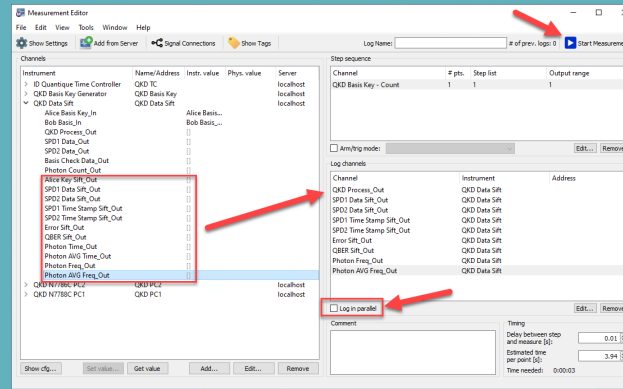

Eavesdropper Simulation

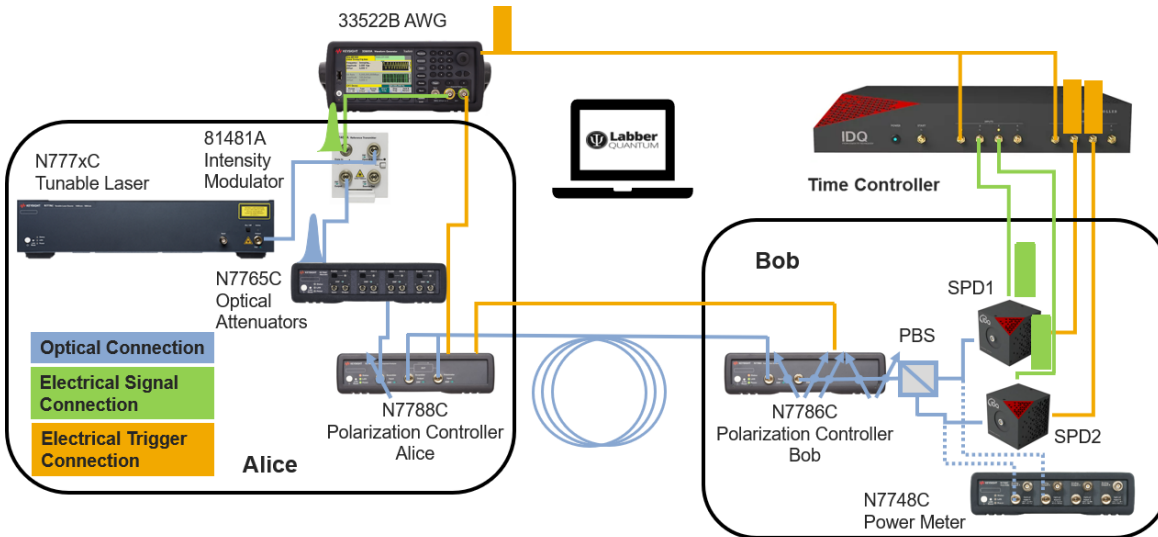
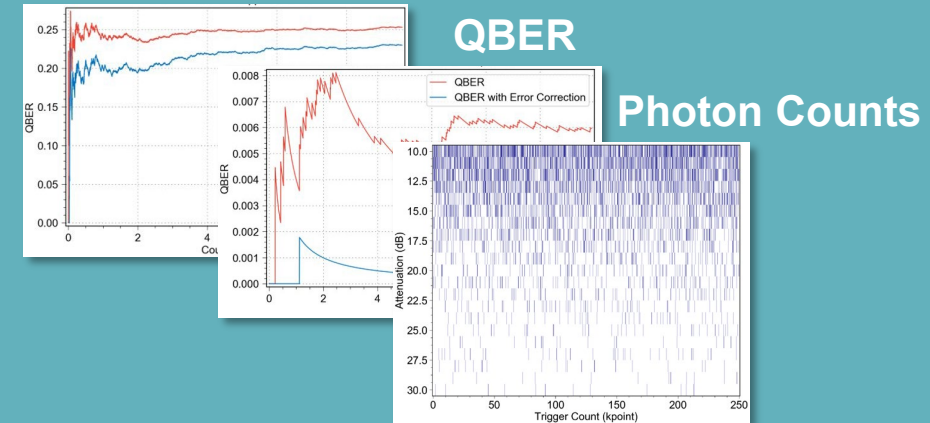

- **Classic / Quantum Scattering Experiments**
- **Single Photon Detector (SPD) Characterization**
Efficiency vs Wavelength
Jitter Measurements
- **Laboratory DV-QKD Test Bed**
Polarization Qubits
Key Generation and KPI Measurement
Modular design for QKD component testing

Diamond Nitrogen Vacancy Test Solution

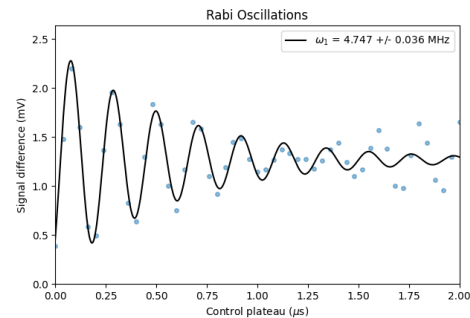
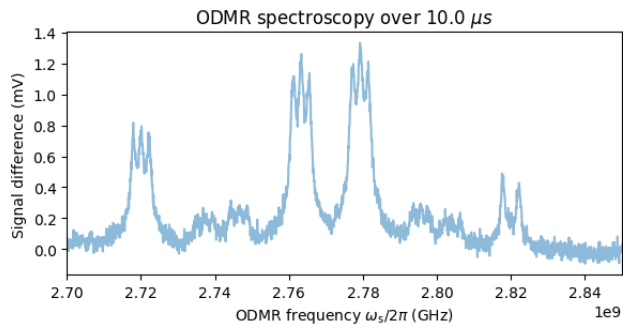
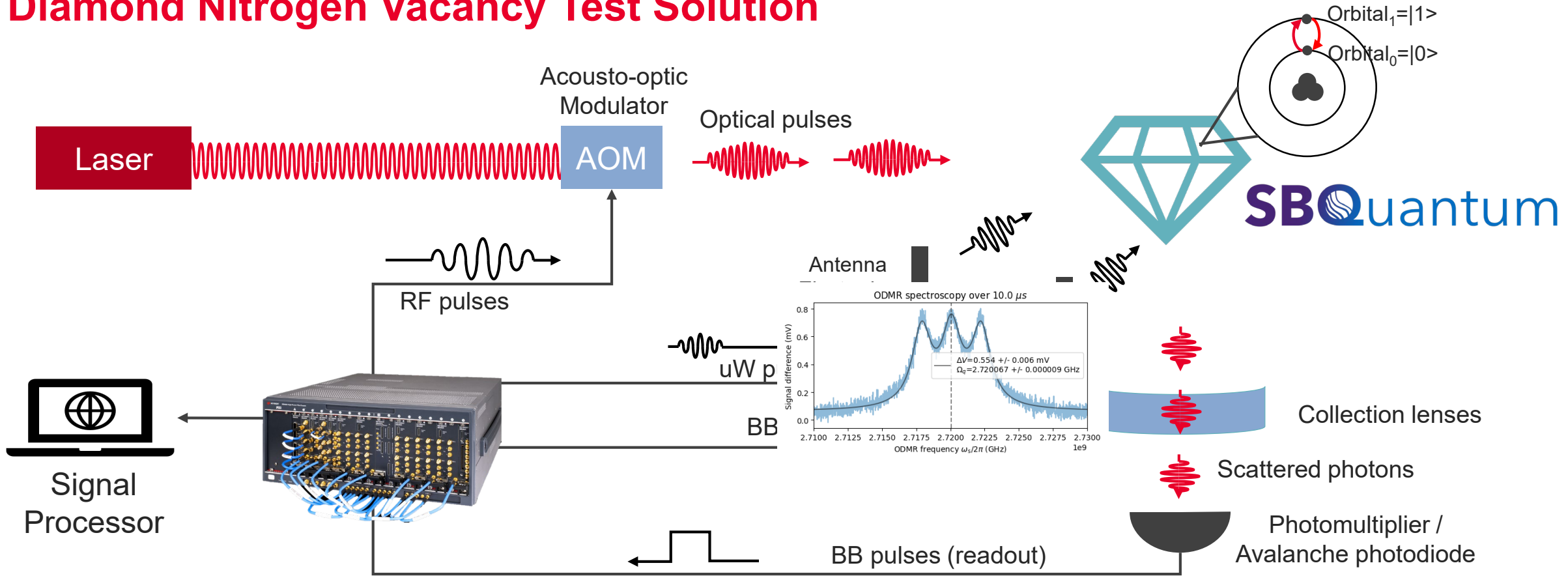

US Quantum Tech Showcase in Washington D.C.

Working with Government to further invest in Quantum

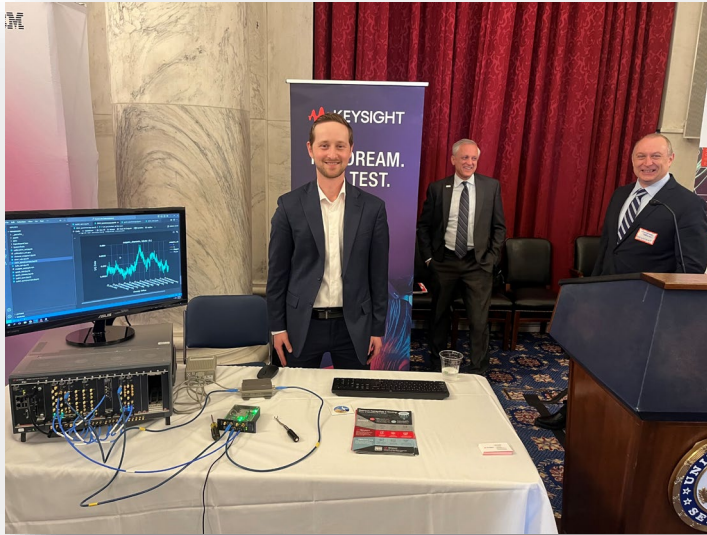

Keysight and Our Involvement in Korea

Committed to Korean Ecosystem, Committed to Fault Tolerant Quantum Computing

- **Strengthen** the Quantum Ecosystem
- **Accelerate** innovation in quantum
- **Collaborate** with industry and research

We welcome you to our **Booth** at **S10** for more information!

Demos:

- Quantum Control System For Qubits
- Single Photon Detection
- Diamond Nitrogen Sensor Testing

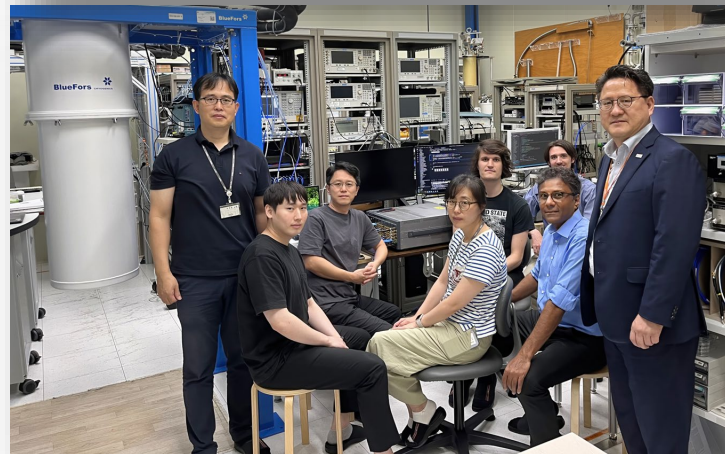
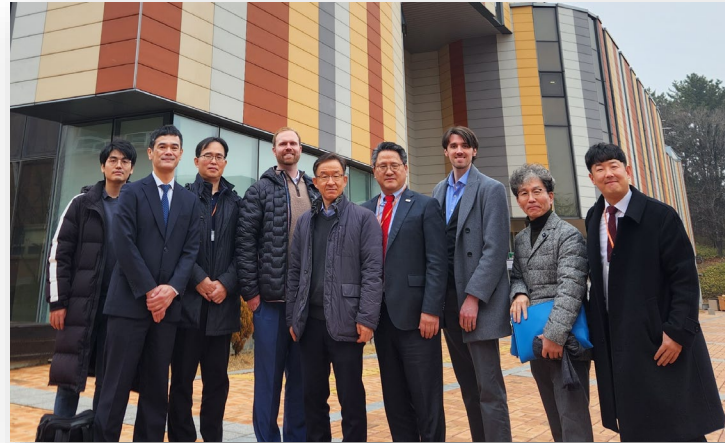



BLUE
FORS

BLUE
FORS

