

QuEra

#TheBestWayToQuantum

# QuEra: Neutral Atom Quantum Computing

 June, 2024

Tommaso Macrì, [tmacri@quera.com](mailto:tmacri@quera.com)

# About QuEra

- Based in Boston, we employ 50+ scientists and engineers from Harvard, MIT, and other top-tier institutions.
- We have a clear path to the “holy grail” of quantum computing: **large-scale, error-corrected devices**.
- We productize innovations from QuEra and our MIT/Harvard collaborators at **record speed**.
- Dozens of organizations and hundreds of users already execute jobs on our quantum computer.
- We are hiring, check current job opportunities!



# Transitioning from Physical to Logical Qubits

Top row: Academic demonstrations at Harvard and MIT

Bottom row: Commercialization activities at QuEra



**Nov '17**

Programmable quantum processor with 51 qubits

Ref: Bernien (Harvard) et al., Science 2017

**Jul '21**

First demonstration of control over 256 atoms with scientific discoveries

Ref: Ebadi (Harvard) et al., Nature 2021

**Jul '19**

QuEra founded as a spin-off of Harvard-MIT

**Nov '22**

QuEra neutral-atom 256-qubit machine launches on AWS, the largest quantum computer on the public cloud

**Apr '23**

World record 99.5% two-qubit gate fidelity  
a critical breakthrough for QEC

Ref: Evered (Harvard) et al., Nature 2023

**Dec '23**

Breakthrough demonstration of algorithms with multiple logical qubits

Ref: Bluvstein (Harvard) et al., Nature 2023

# Error-Corrected Quantum Computing Roadmap

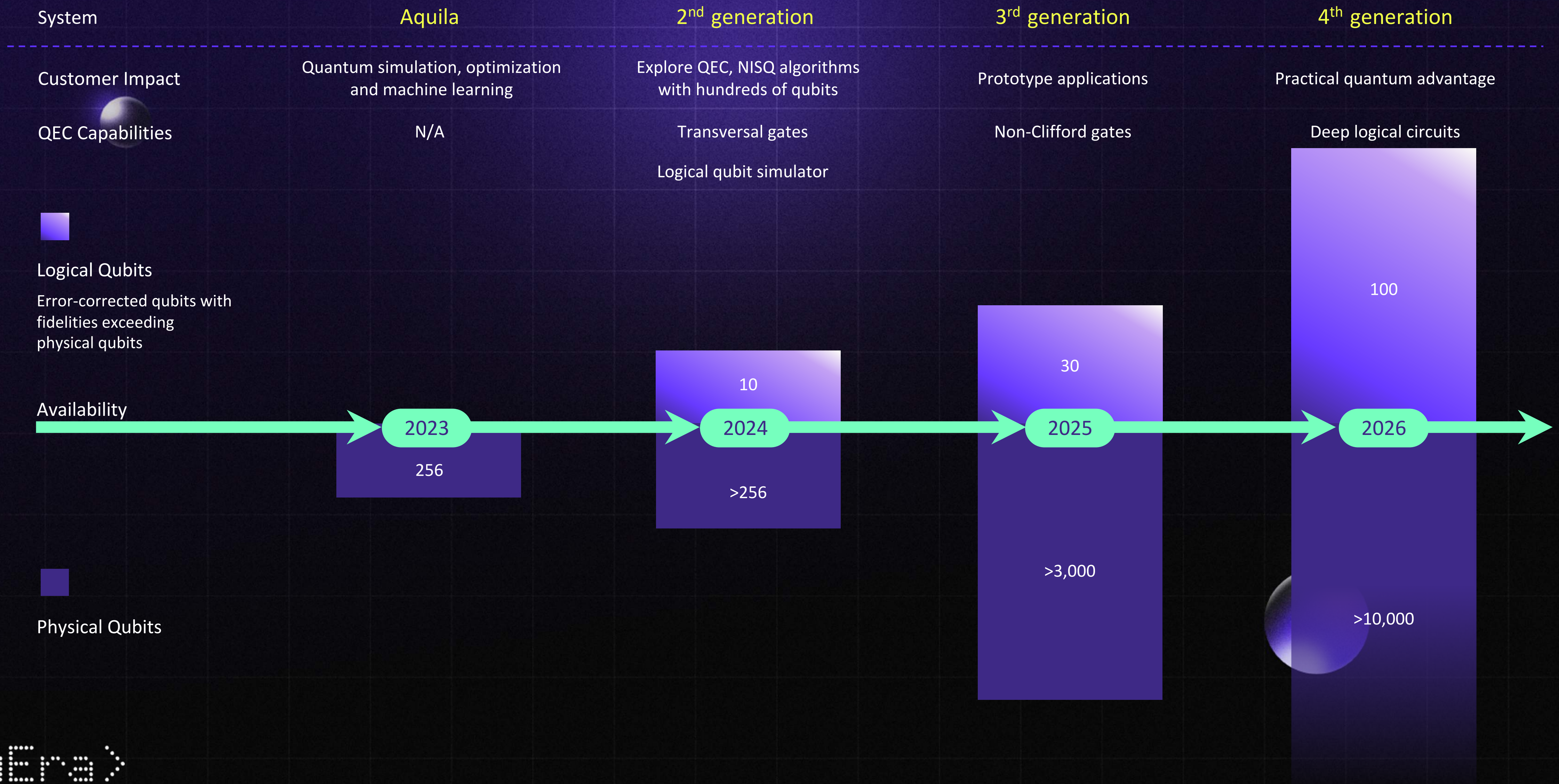

10.1 Era >

Technology introduction

**How neutral-atom computers work**

# Neutral Atoms: the Most Promising Approach

- **Nature's perfect qubits**

We use atoms – all identical – pure and resistant to noise, unlike alternative approaches.

---

- **Easier to scale – more qubits**

256-qubit machine today, 1000 qubits already demonstrated at Harvard lab, can scale to 10,000+ qubits without requiring interconnects.

---

- **Efficient**

Reconfigurable layout and movable qubits lead to efficient problem encoding and easier error correction without connectivity limitations.

---

- **Operate at room temperature**

Our room-temperature approach can scale without any cryogenics, thereby reducing complexity and footprint.

# Analog and Digital Operation Mode

$^{87}\text{Rb}$

Analog mode

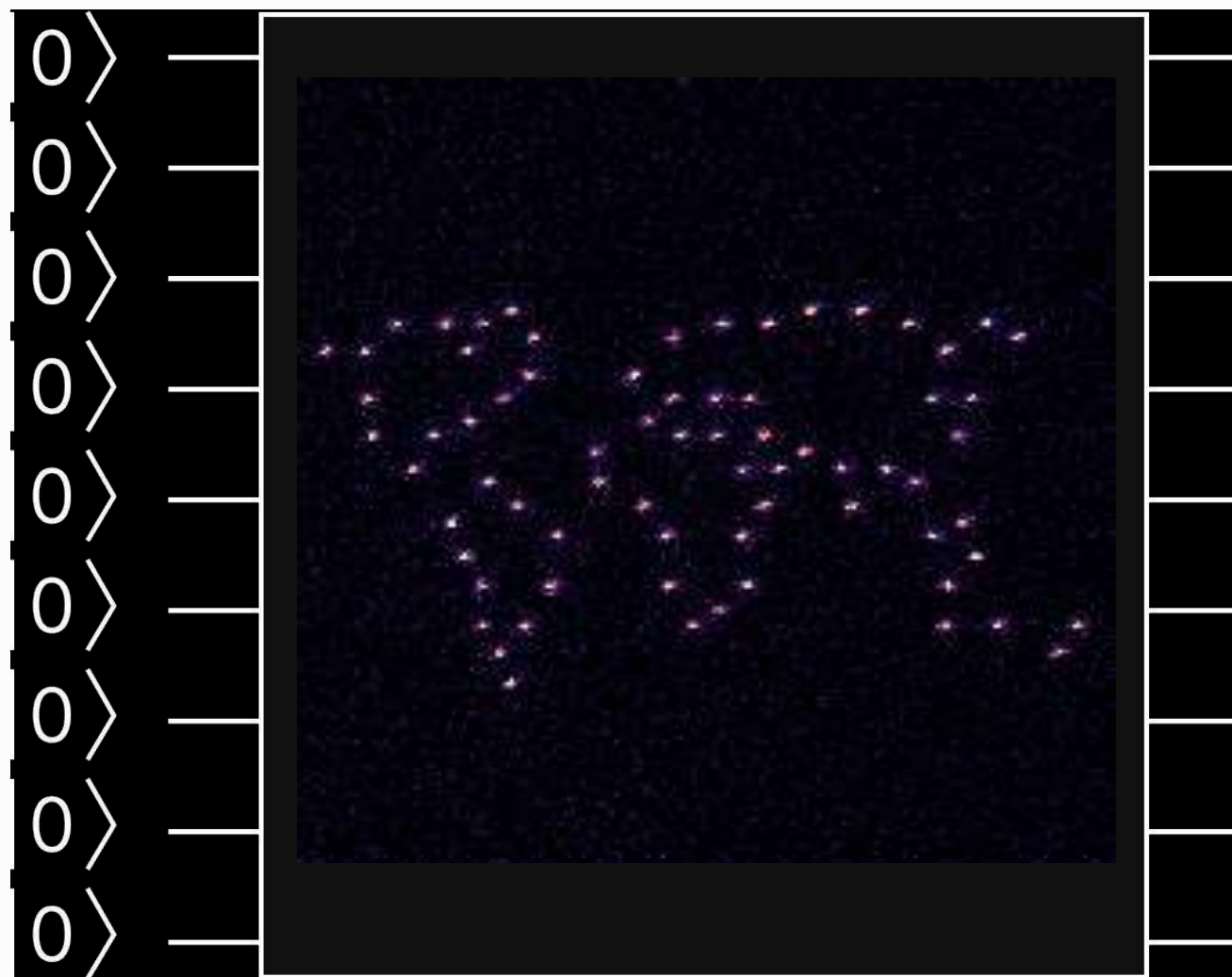

Strong long-range interactions

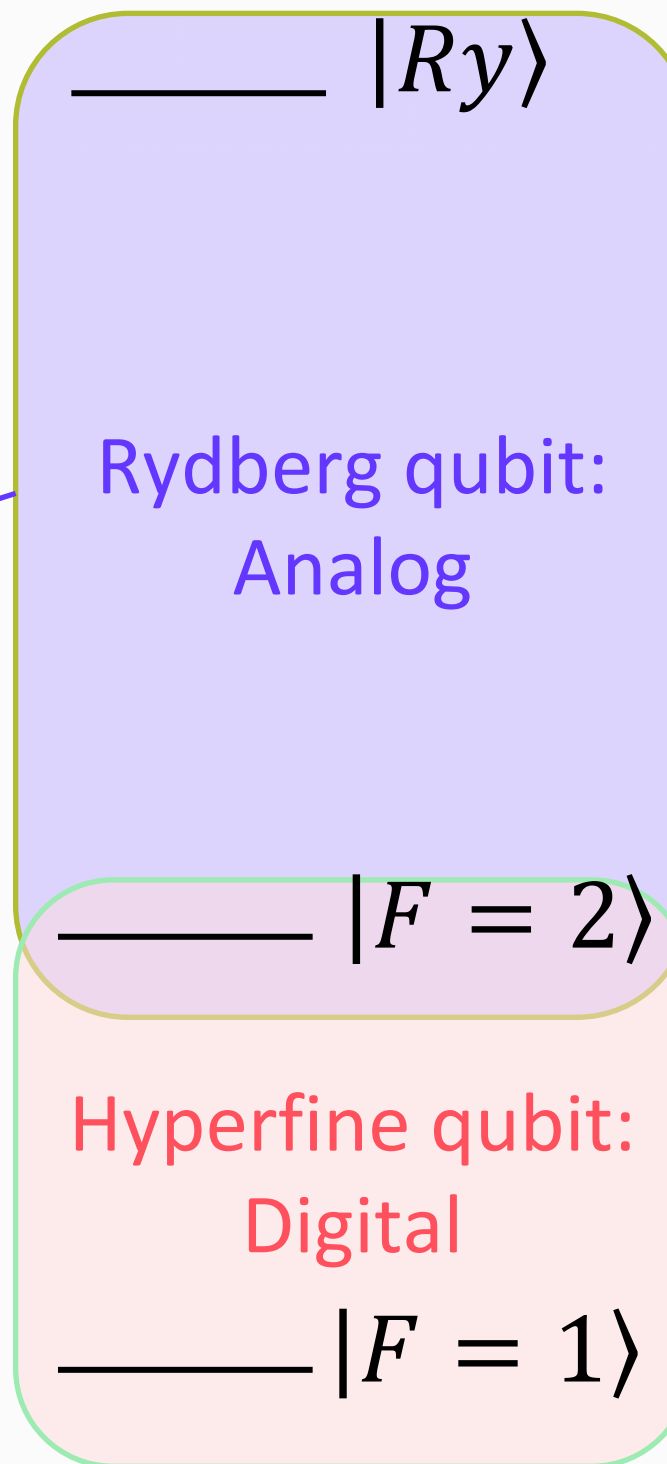

Long coherence time

Digital gate-based mode

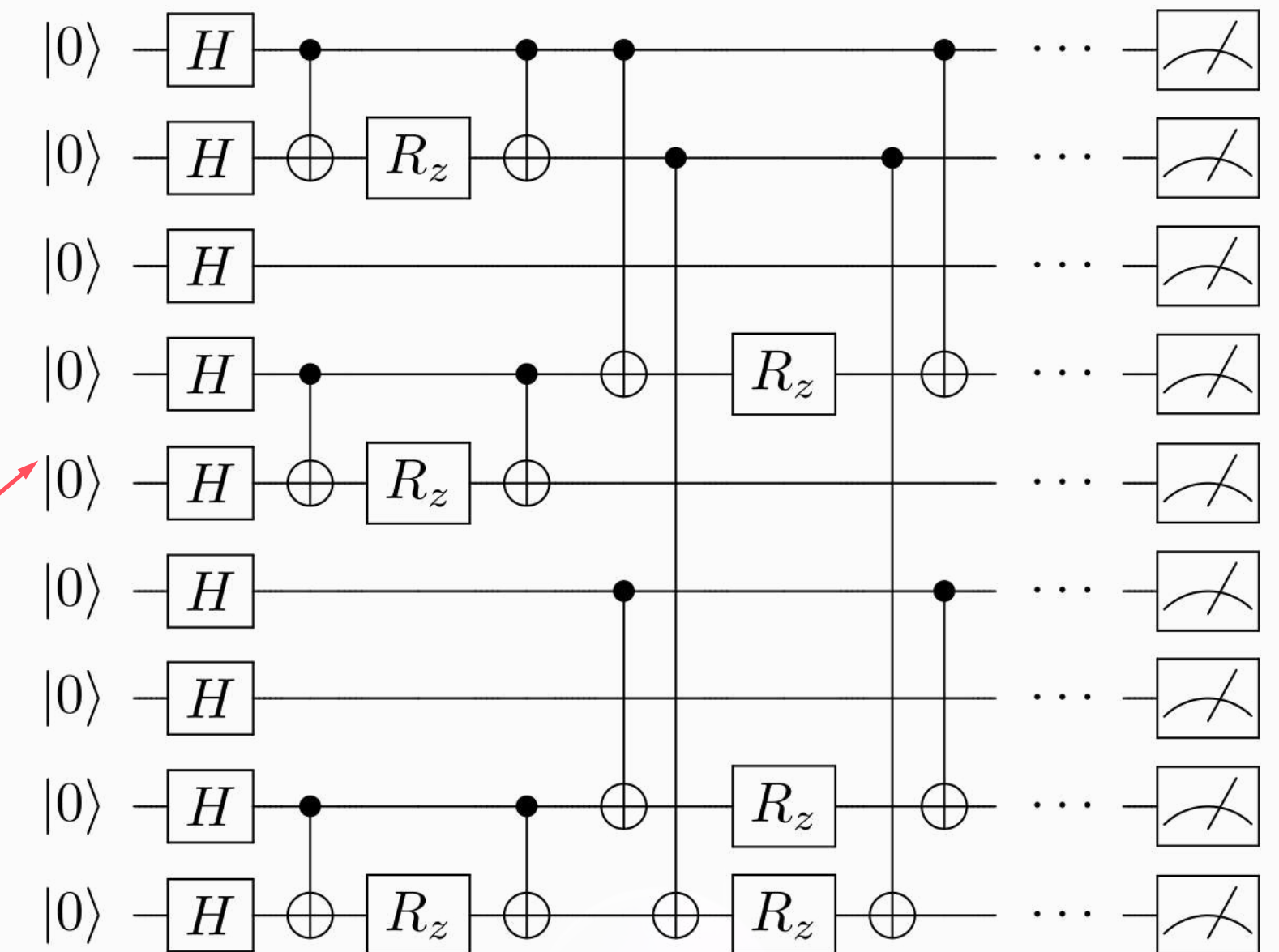

# Entanglement through Rydberg blockade

## 3 basic building blocks

- Atoms (Rubidium 87)
- Optical tweezers
- Rydberg blockade

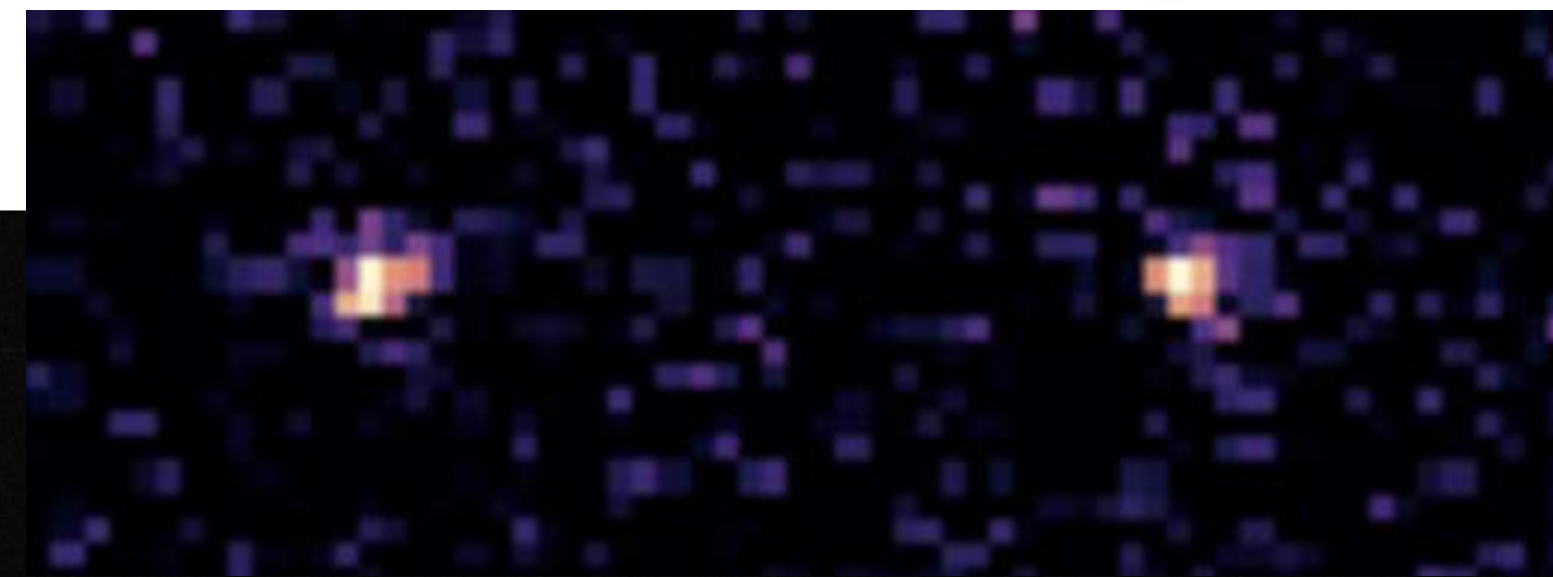
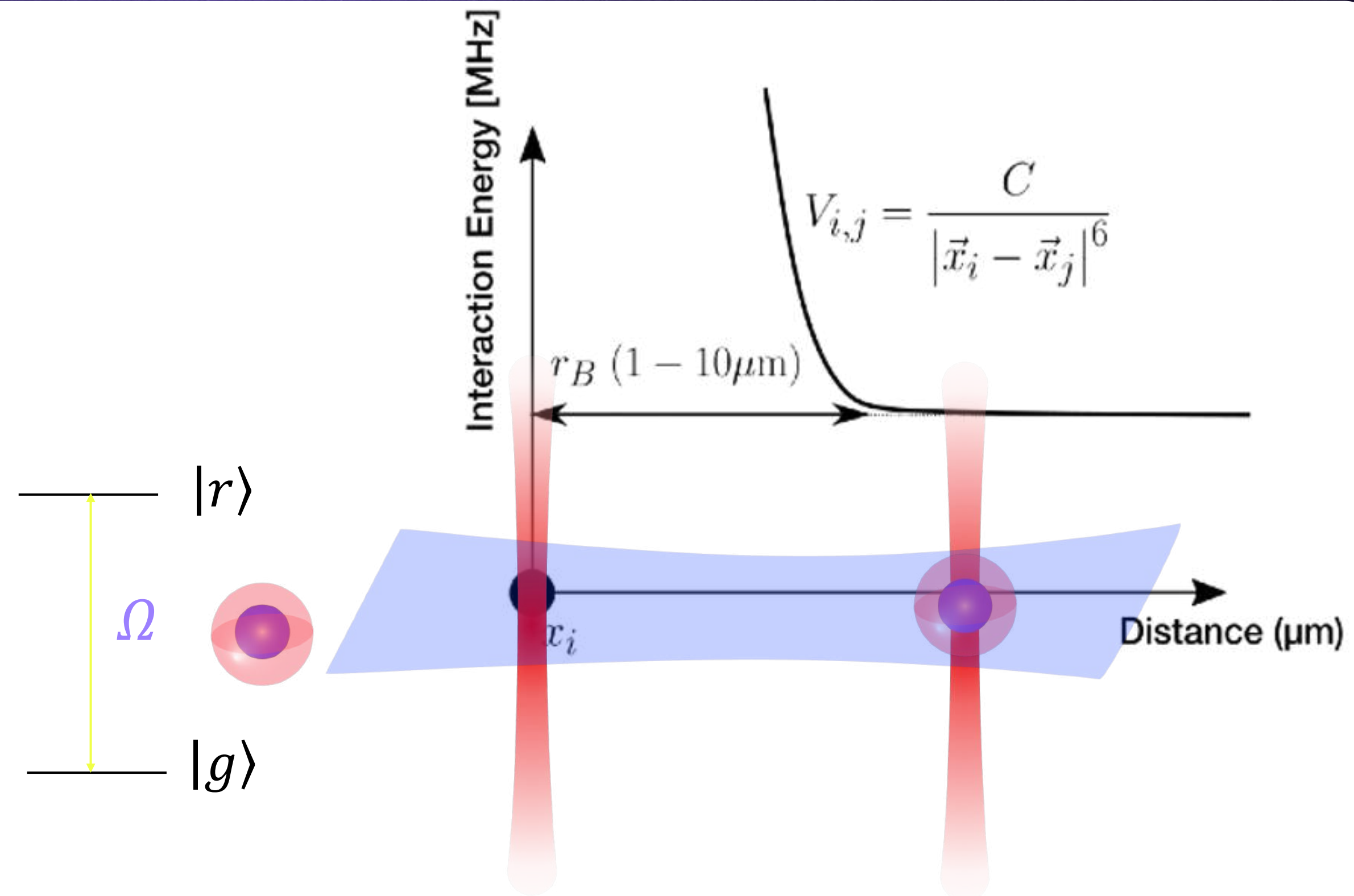

# Entanglement through Rydberg blockade

## 3 basic building blocks

- Atoms (Rubidium 87)
- Optical tweezers
- Rydberg blockade

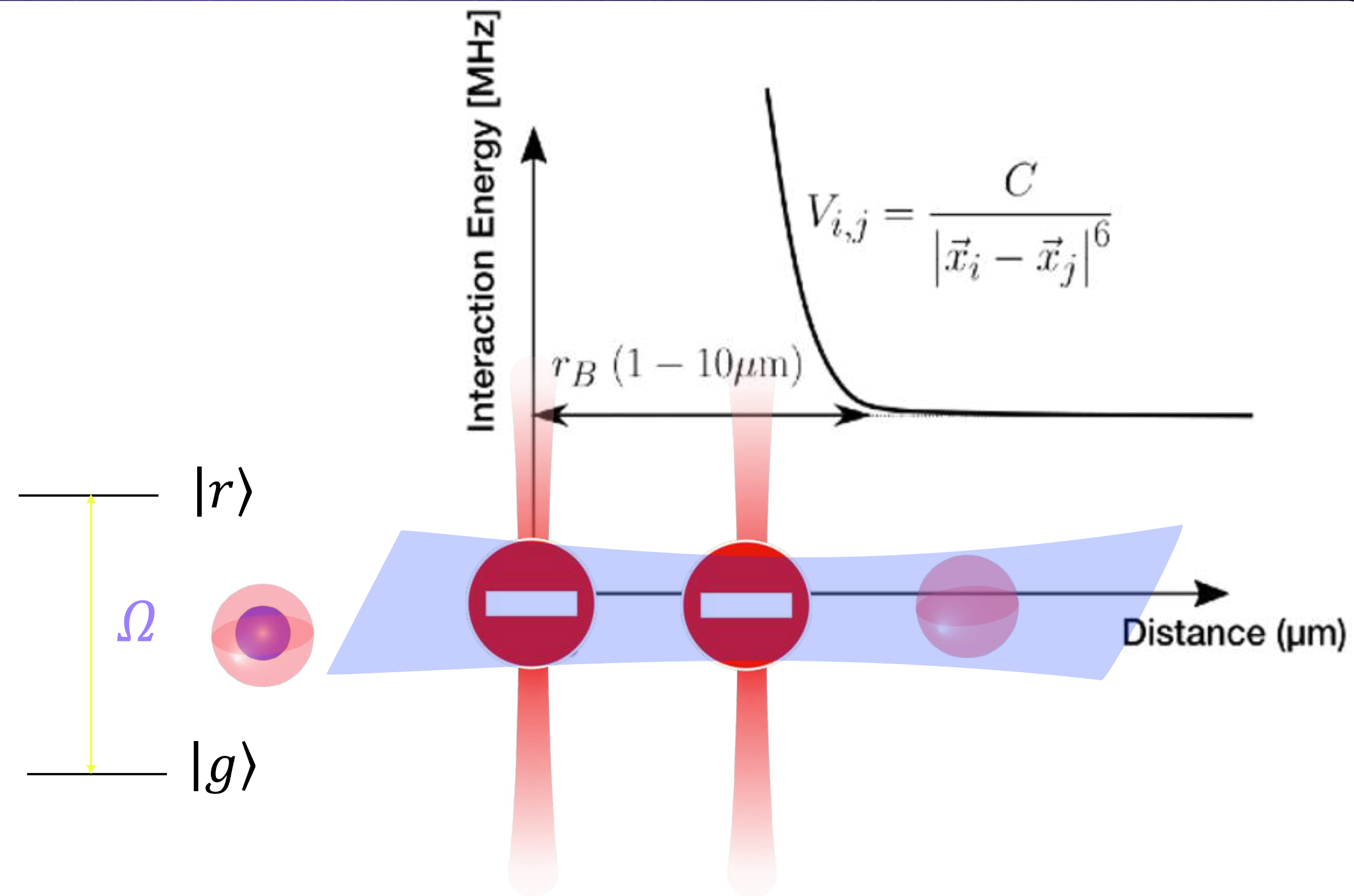

# Aquila: Our 256-Qubit Analog Quantum Computer

- The first and still the world's **only** publicly-accessible quantum computer based on neutral atoms.
- Increased availability from 10 to over **100 hours per week**.
- Key applications: **simulation, optimization, machine learning**.
- The use of Aquila has resulted in several exciting scientific publications.
- Through “premium access”, customers can **engage directly** with QuEra scientists.



# What problems can QuEra's Aquila solve?

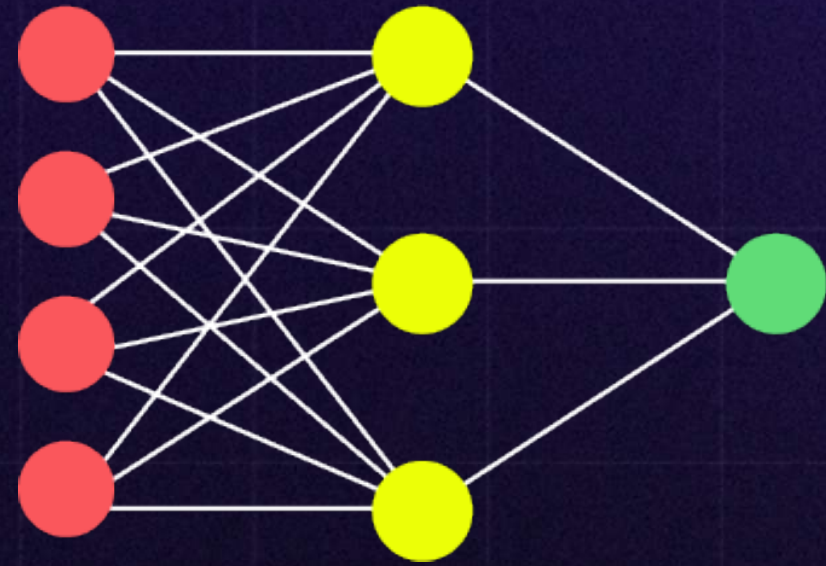

## Machine learning

- Classification
- Regression and prediction
- Reservoir computing

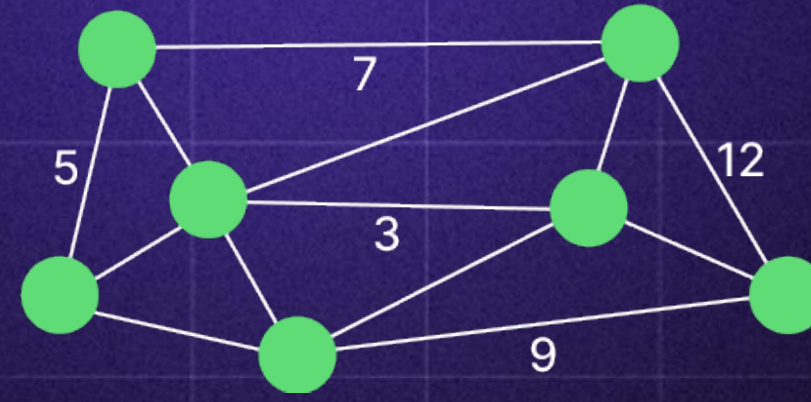

## Optimization

- Maximum independent set
- Non-native optimization, e.g. QUBO
- Commercially-relevant problems



## Simulation

- Equilibrium quantum phase of matter
- Non-equilibrium quantum dynamics
- Lattice gauge theories

Check out the [Aquila Whitepaper](#): Wurtz et al., arXiv:2306.11727

# Reservoir computing with neutral atoms

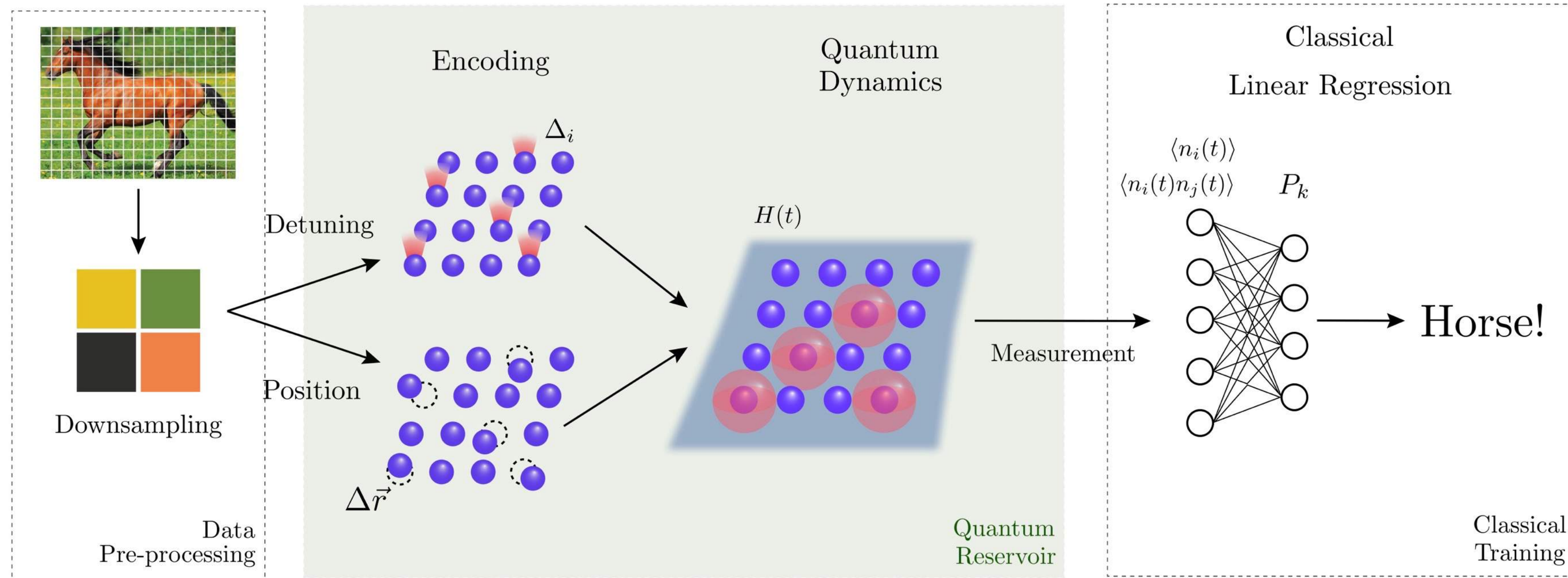

**Feasible.**

Suitable for today's machines

**Trainable.**

No vanishing gradients

**Fast.**

Training is classical

# Preliminary Results on MNIST (Simulation)

10000 training data + 1000 testing data  
Simulation with Bloqade

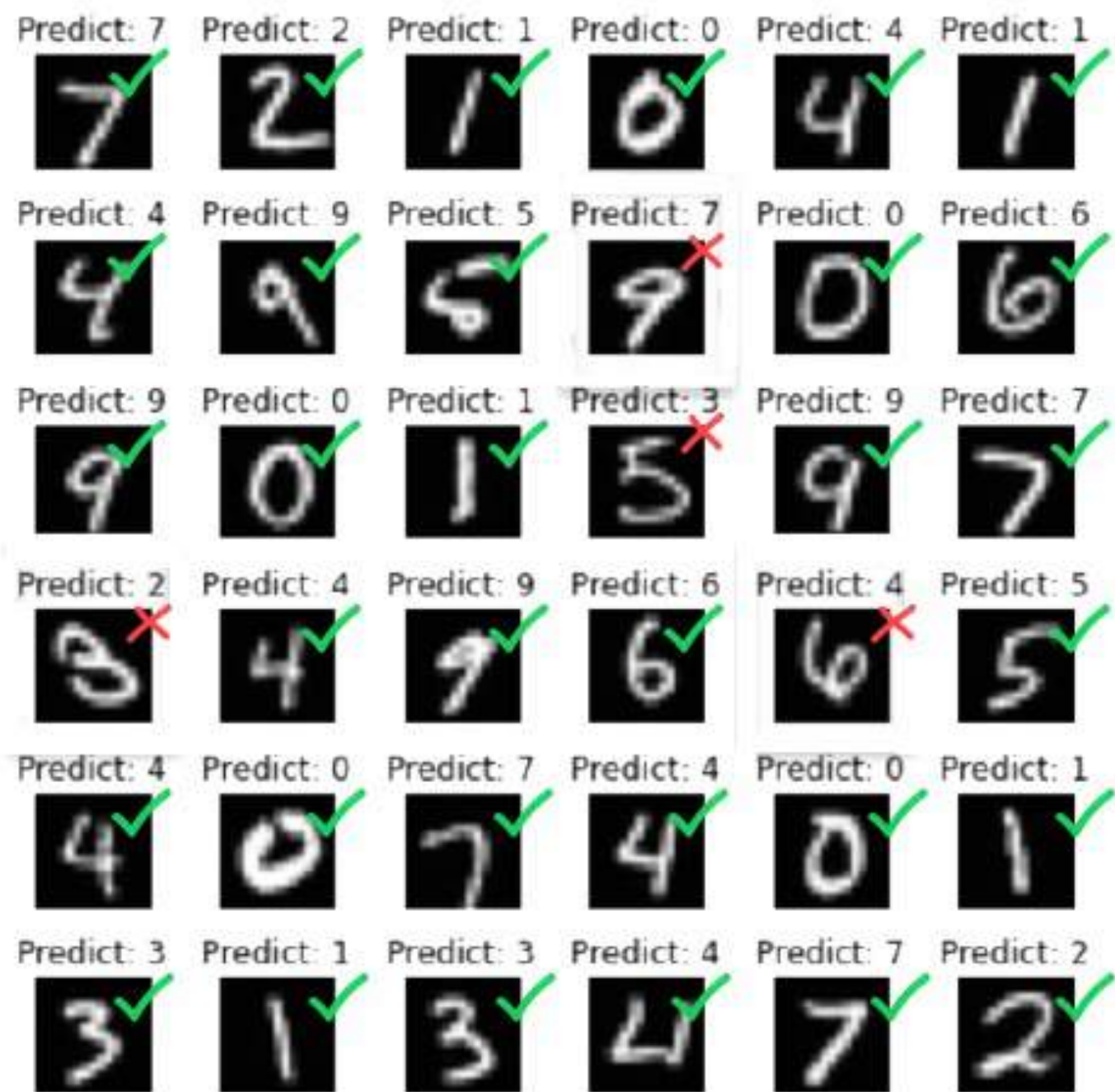

92% accuracy with quantum reservoir learning  
Quantum is on par with complex classical neural nets

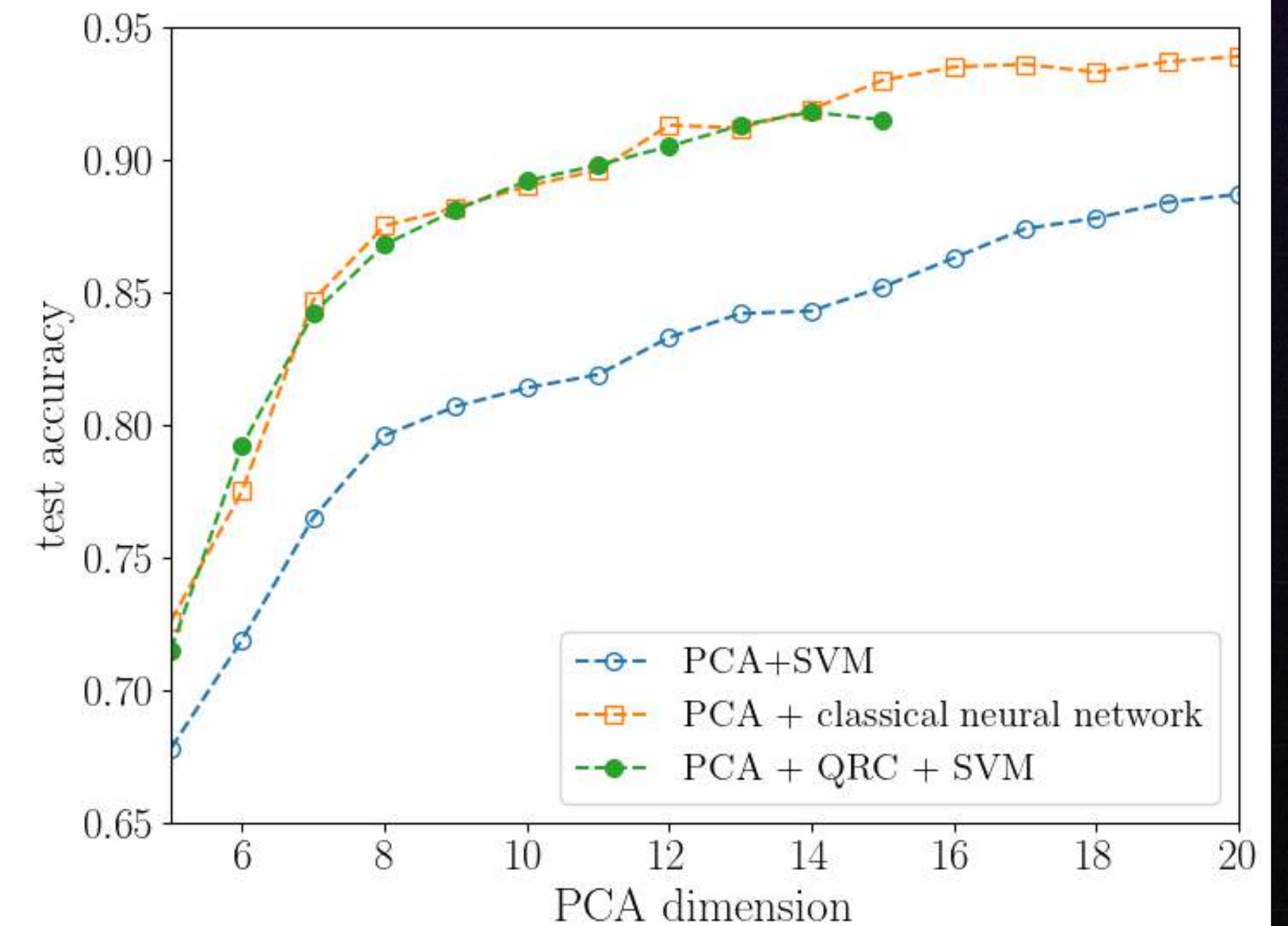

# New Directions in Dev: HEP, Chemistry, Cond. Matt.

## String Breaking

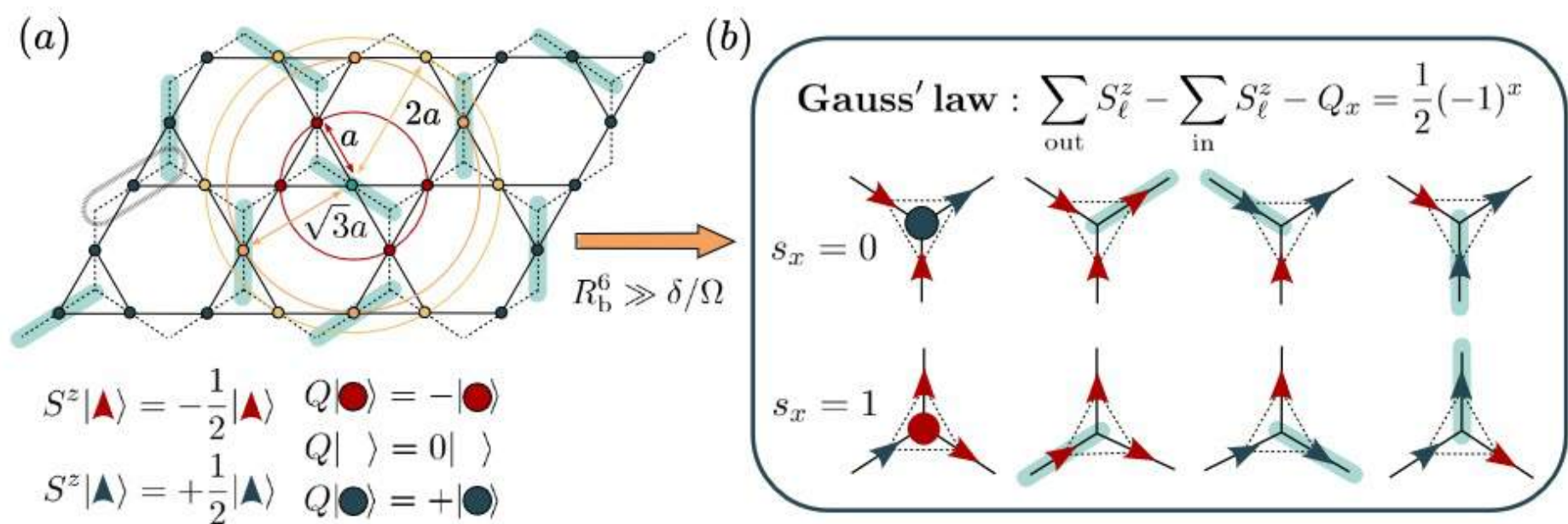

Collab. with Peter Zoller (Innsbruck)

## Shastry-Sutherland Lattice

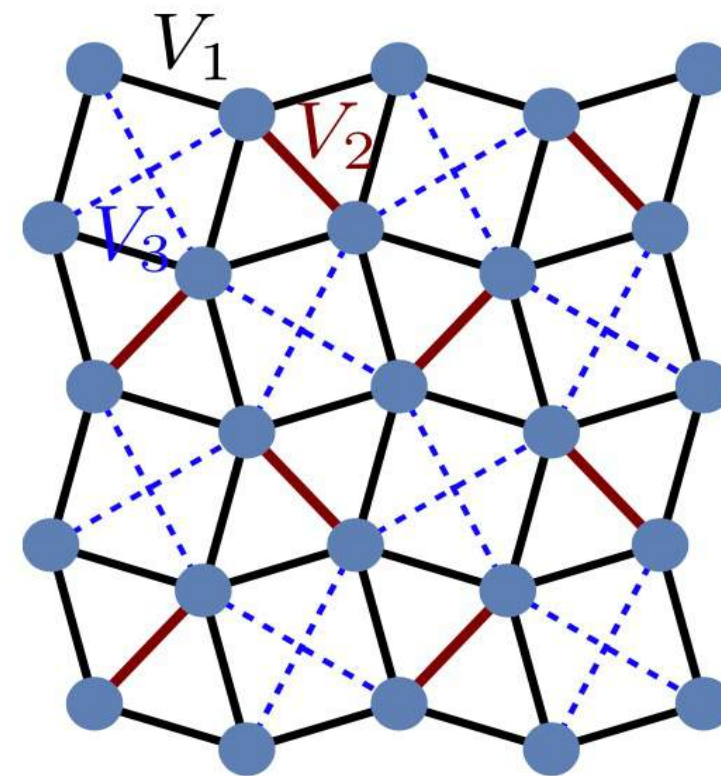

Collab. With Shalaev, Boltasseva, Banerjee groups (Purdue & QSC)

## Trimer Quantum Spin liquids

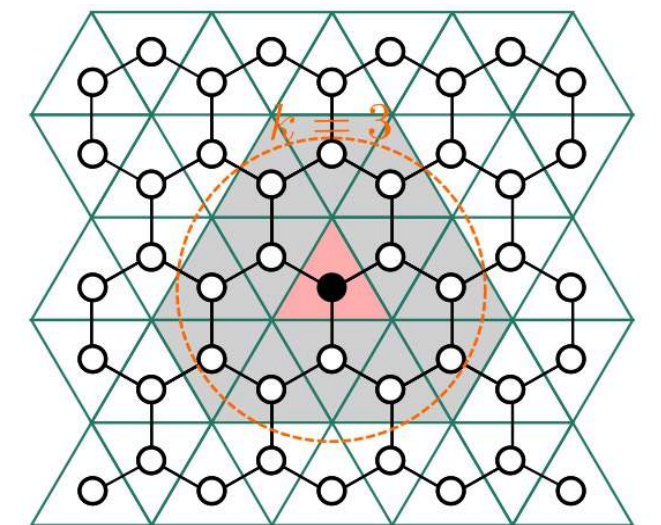
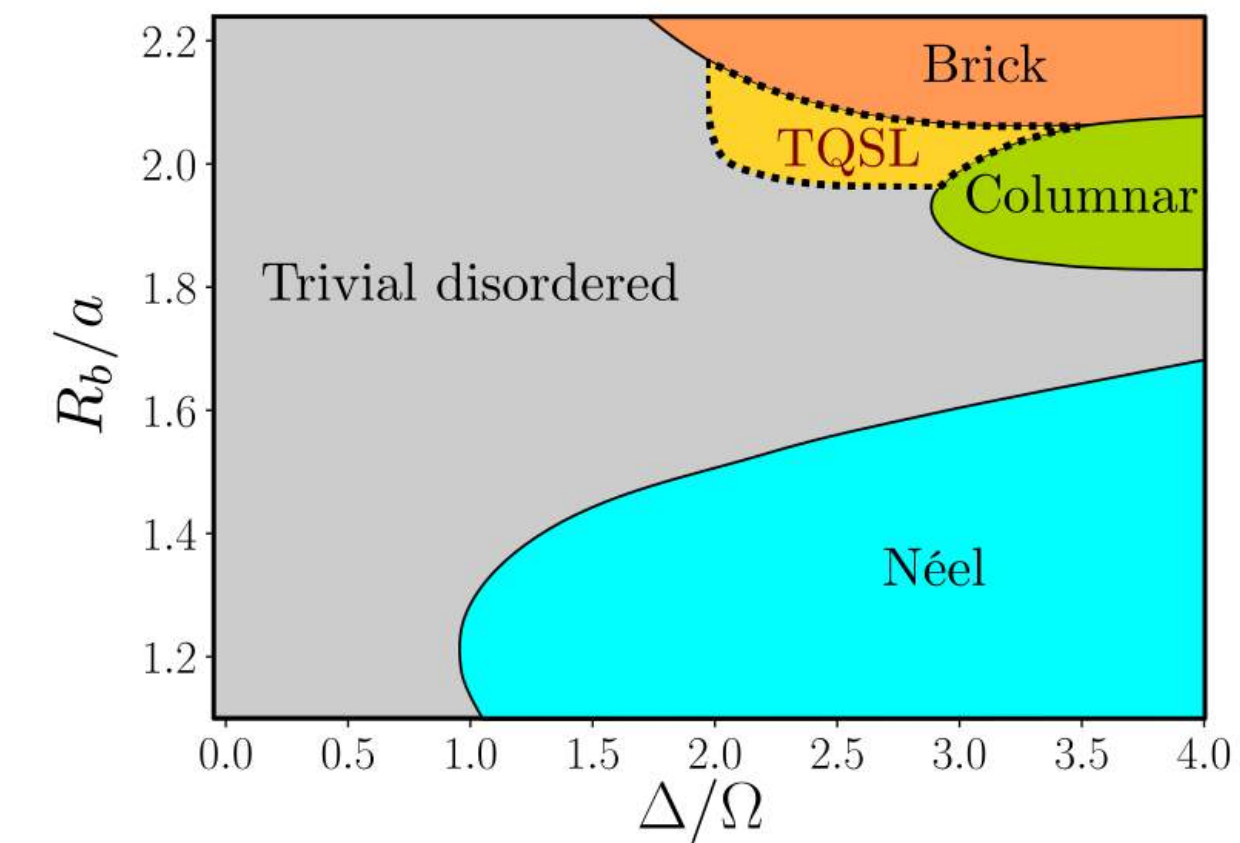

$$2 < R_b/a < \sqrt{7}$$

M. Kornjaca et al., Comm. Phys. 2023

## Quantum Floating Phase

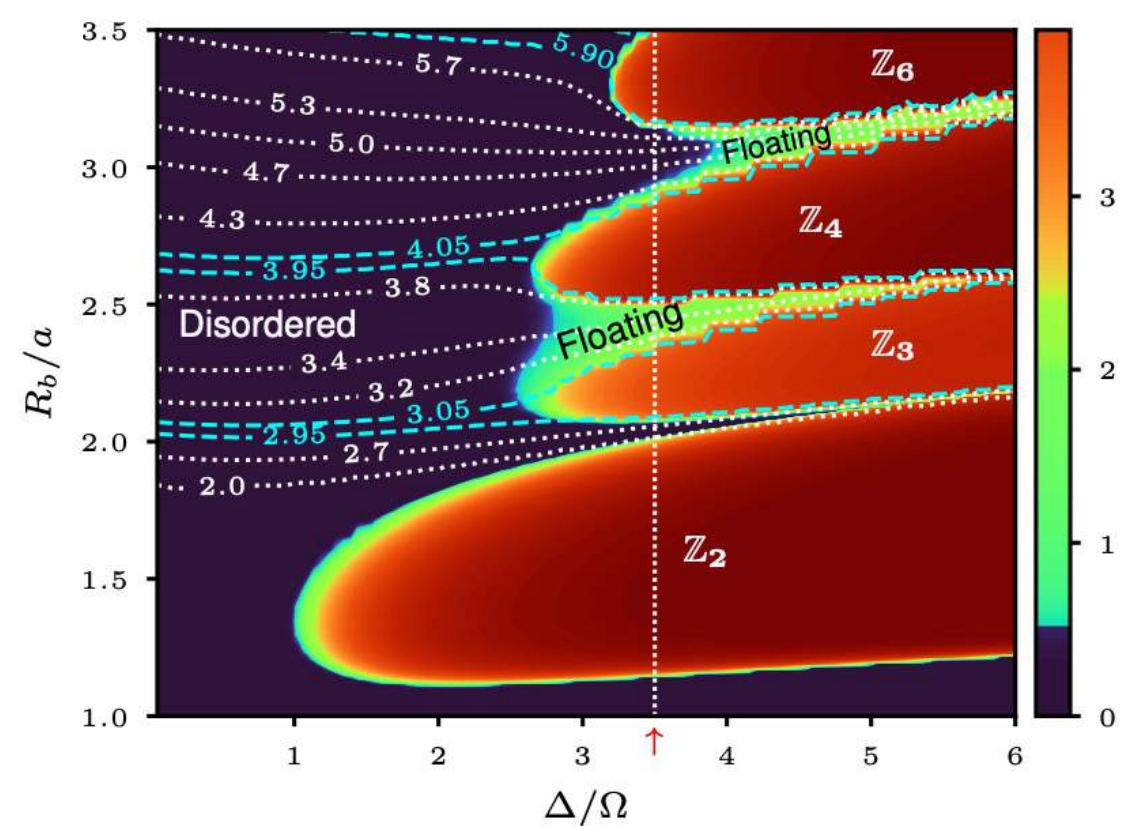

Collab. with Yannick Meurice (Iowa), Shan-Wen Tsai (UC Riverside), arXiv:2401.08087

## False Vacuum Quantum Dynamics

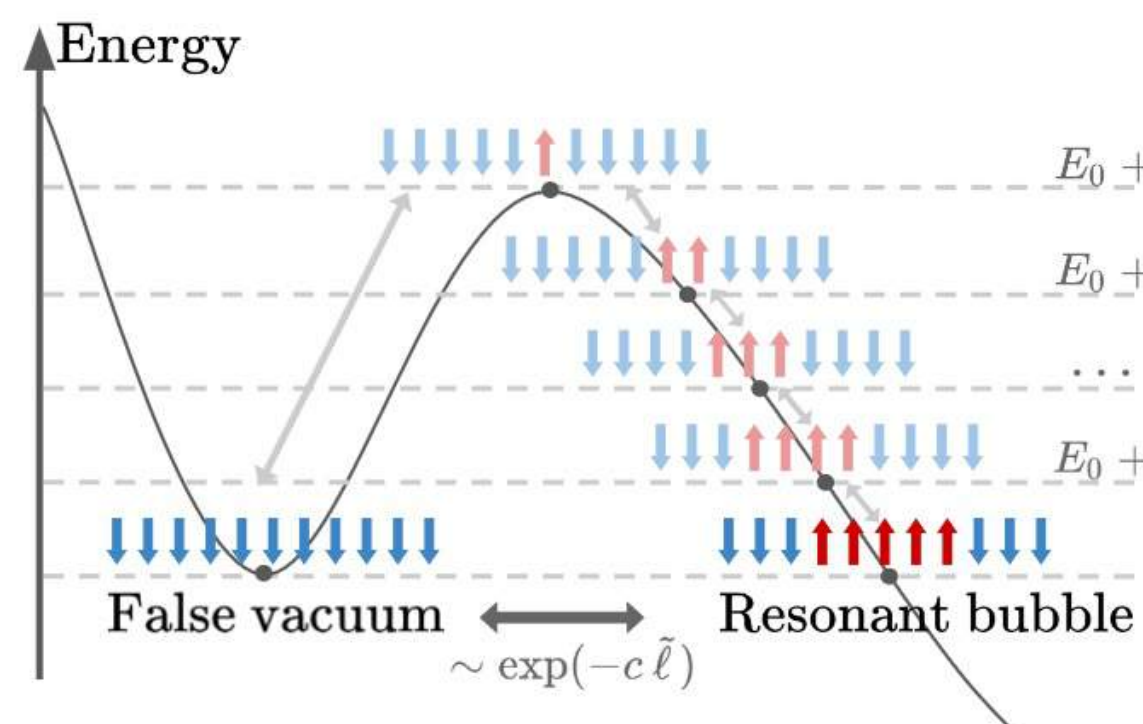

Collab. with NERSC

## Multi-Criticality & Analog Higgs

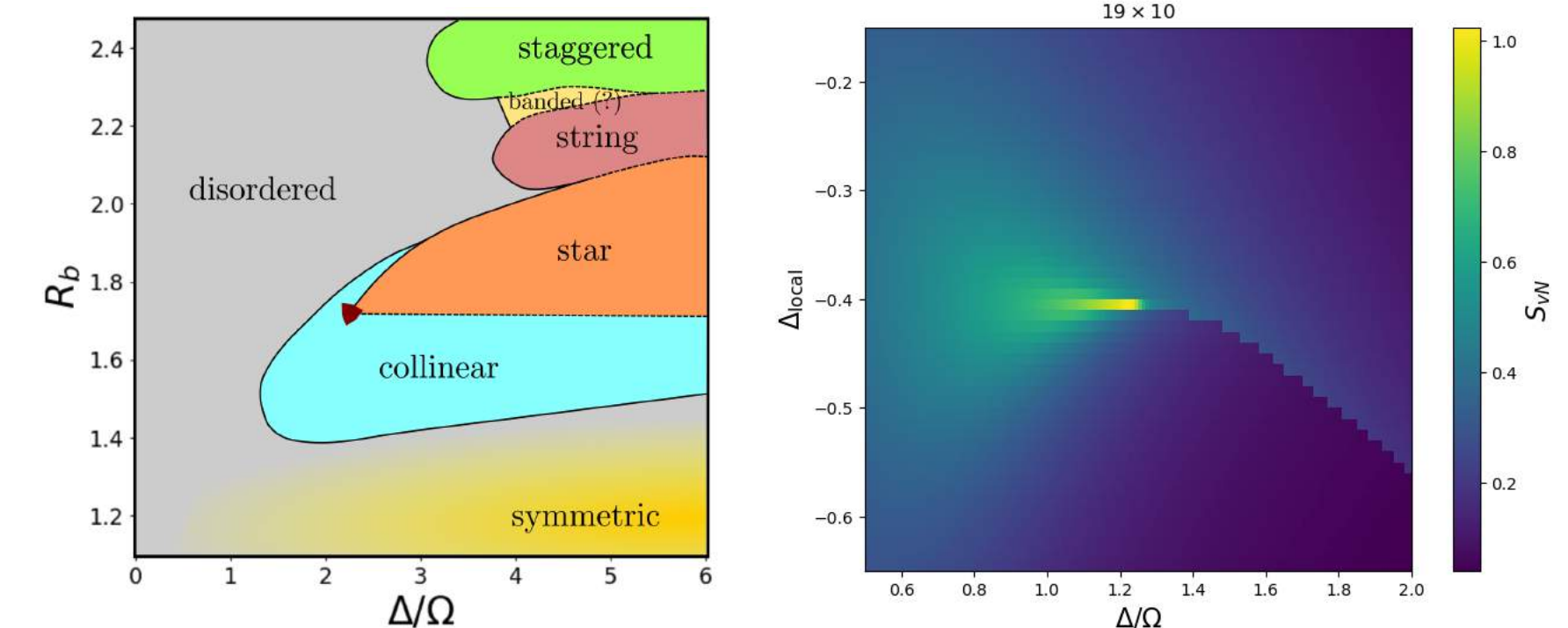

Collab. with NERSC

## Challenges Ahead

# Digital Gate-Based Mode and The Need for Quantum Error Correction

# Why Do Quantum Computers Need Logical Qubits?

✓ The error rates of physical qubits are **too high for most practical applications.**

✓ Logical qubits, the quantum equivalent of the classical repetition code, **improve the error rate to useful levels.**

✓ This reduced error rate allows for **longer and more meaningful quantum algorithms.**

# The Key Building Bloks

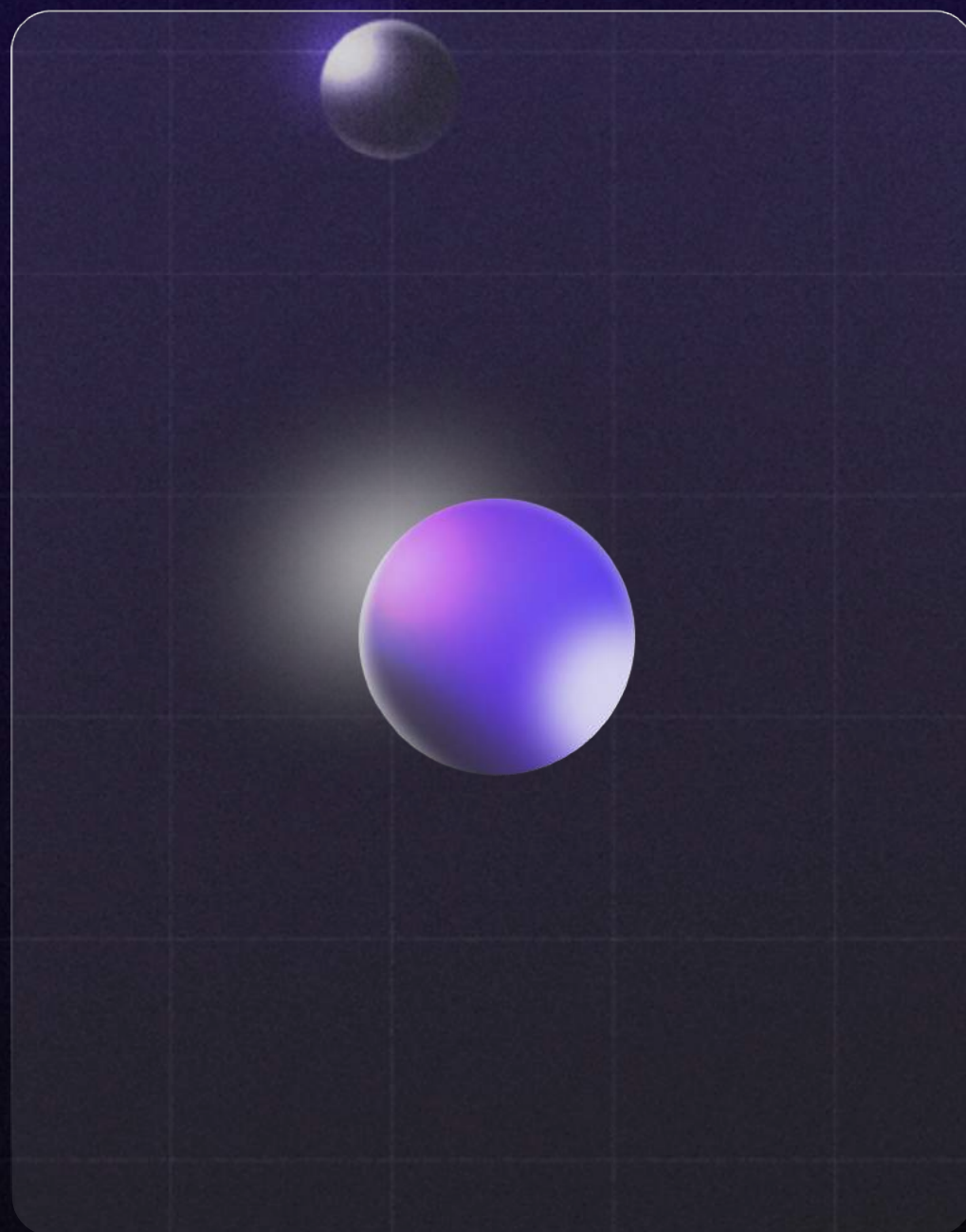

Neutral Atoms

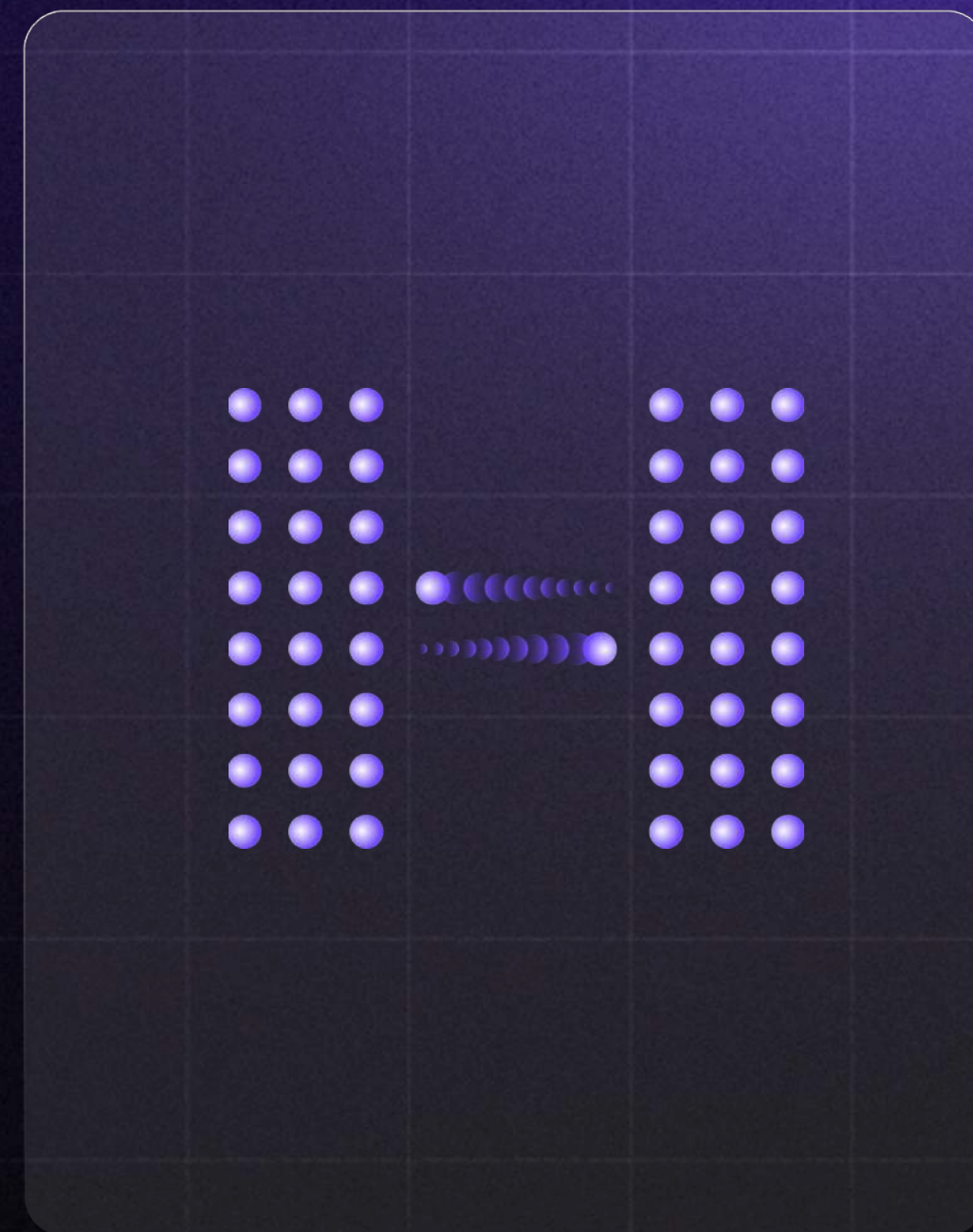

Qubit Shuttling

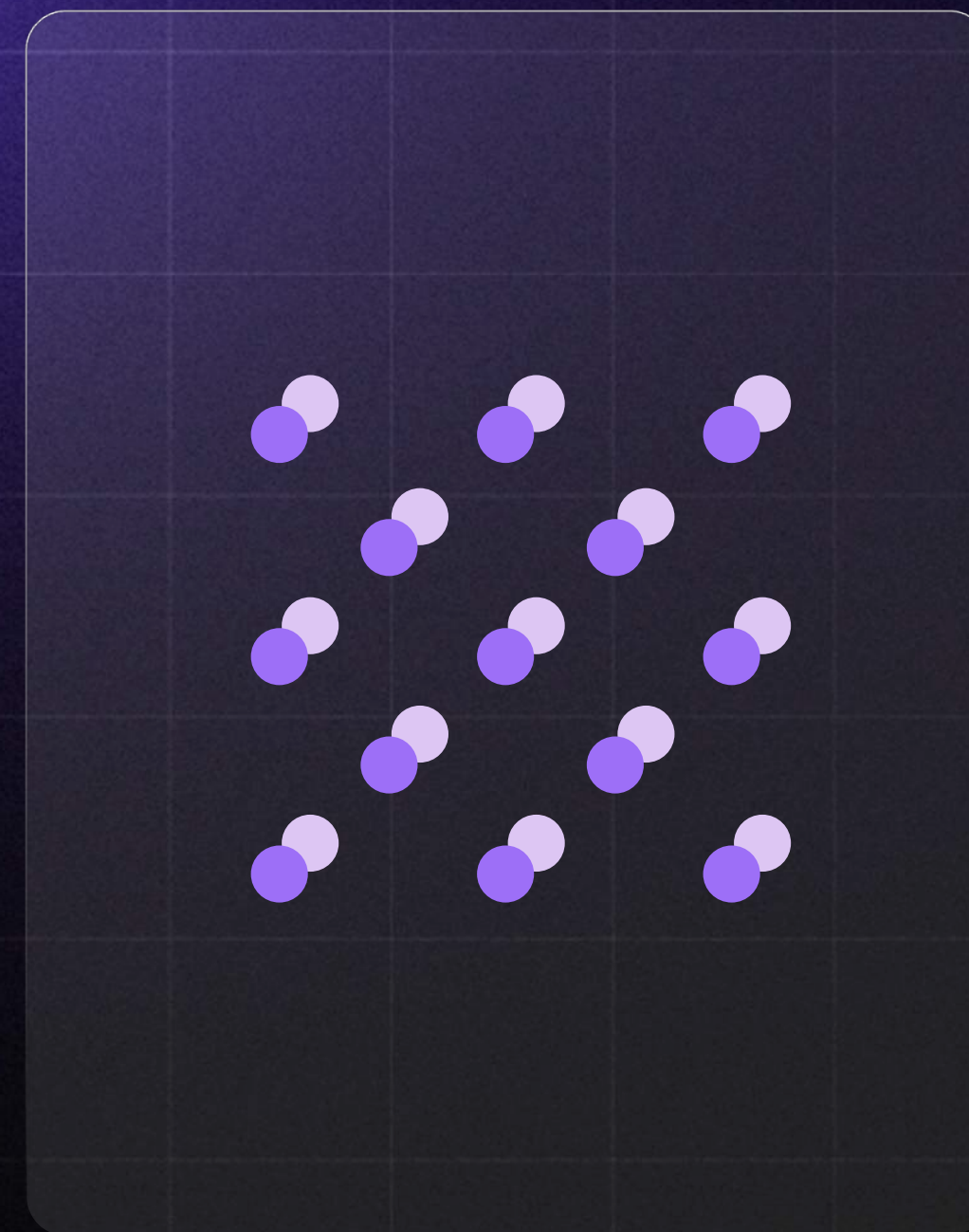

Parallel Operations

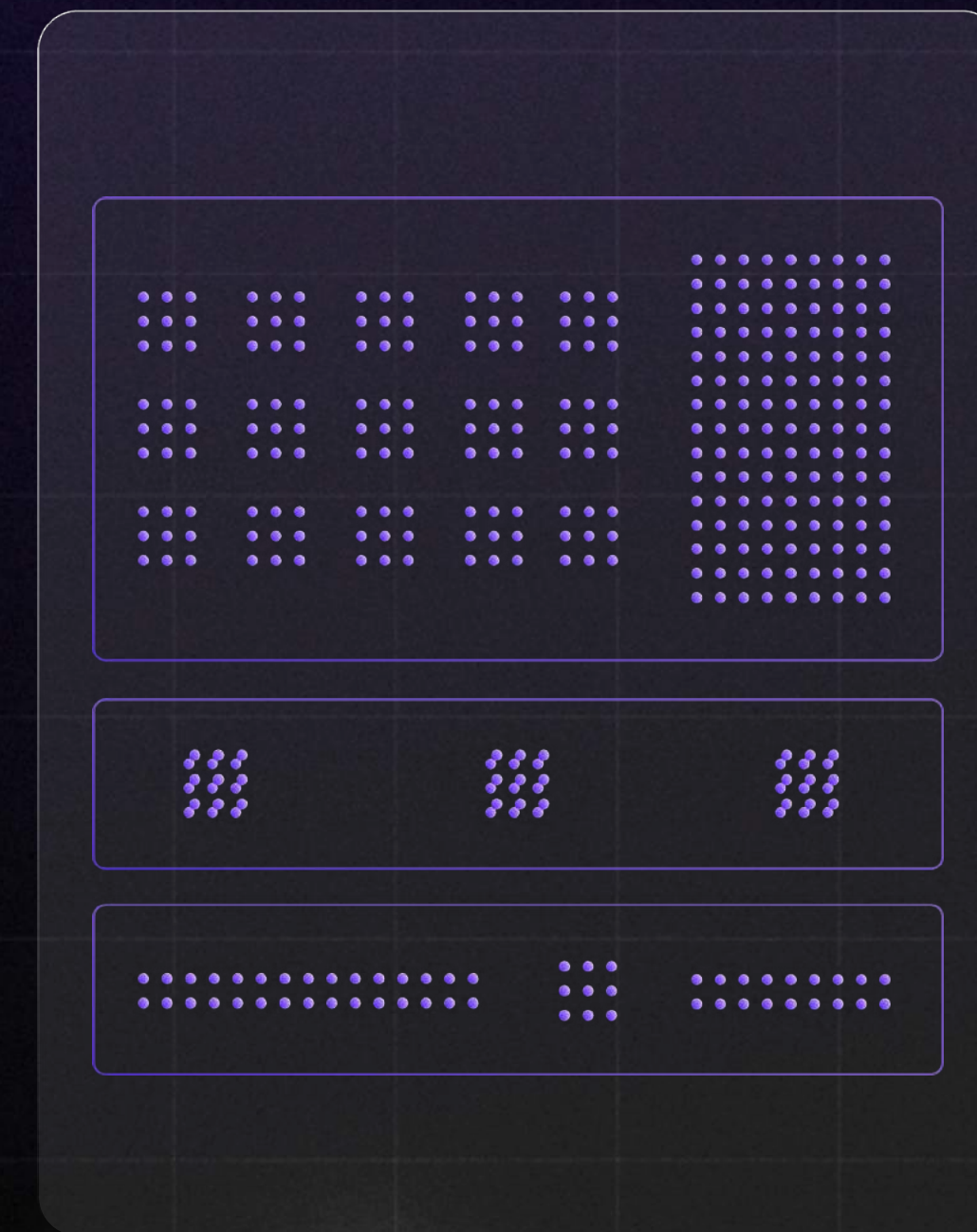

Zoned Architecture

# Zoned Architecture

✓ Storage

✓ Entanglement

✓ Readout

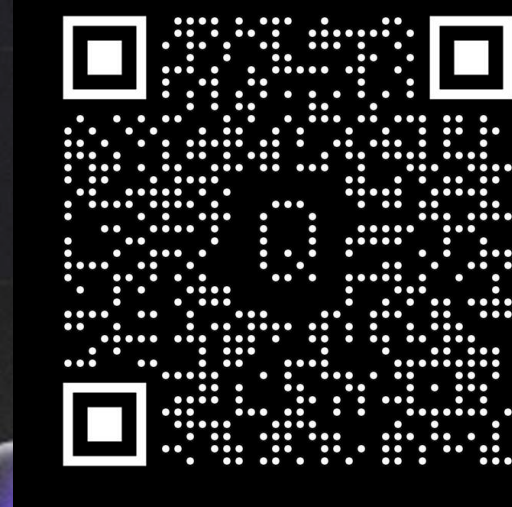
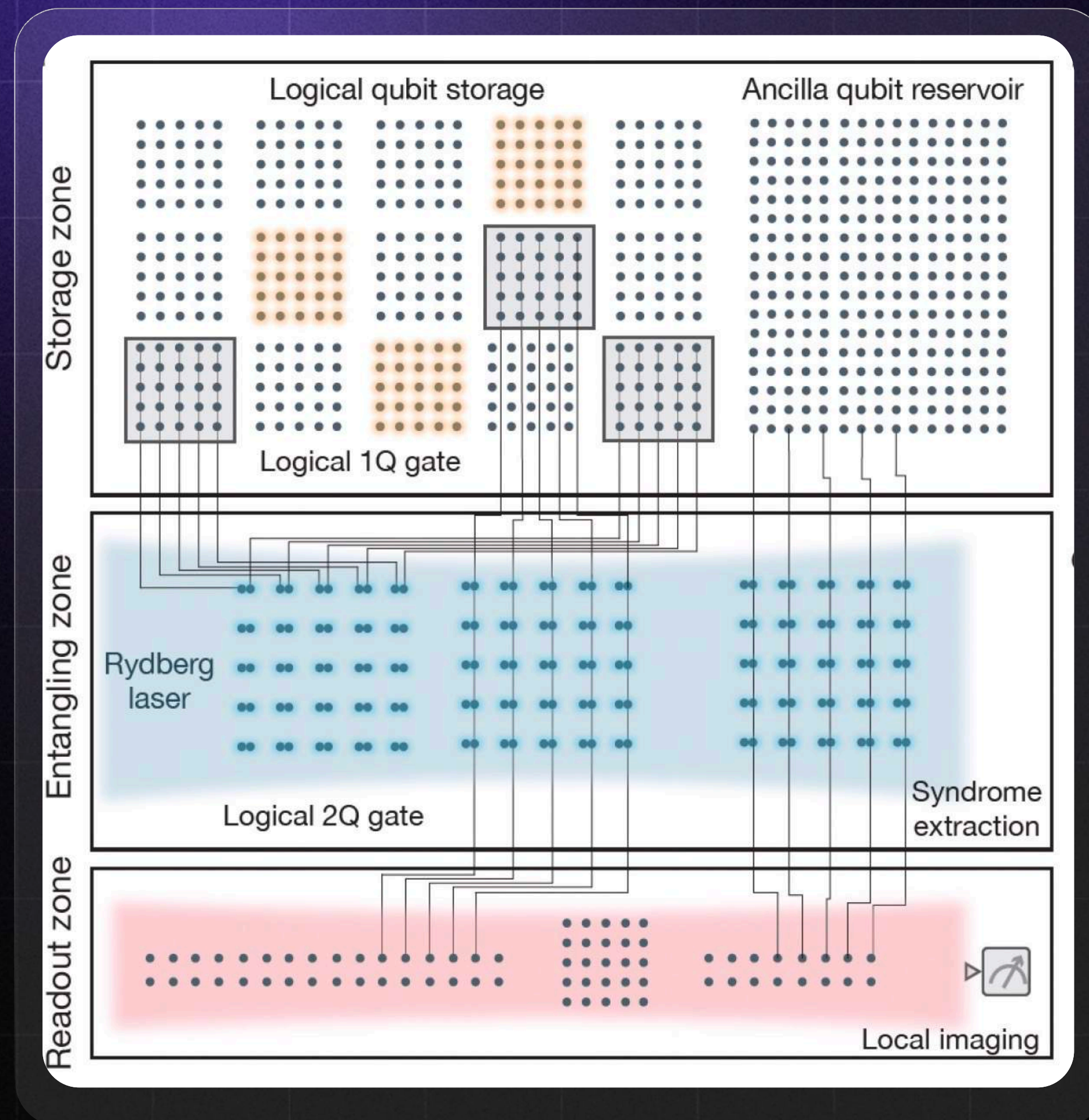

Ref: Bluvstein (Harvard) et al., Nature 2023

# A Recent Major Milestone

# Complex Algorithms on 48 Logical Qubits

“Logical quantum processor based on reconfigurable atom arrays”

Bluvstein (Harvard), et al.



ArXiv link: <https://arxiv.org/abs/2312.03982>



In experiments led by **Harvard University** in close collaboration with **QuEra**, **MIT**, and **NIST/UMD**, researchers successfully executed large-scale algorithms on an error-corrected quantum computer with **48 logical qubits** and hundreds of entangling logical operations.



# Quantum Computing Ecosystem



Government



Venture Capital

- Innovation Centers
- Public Policies for Quantum
- Startup Incubation



Companies



HPC Centers



National Labs



Universities and Research Centers

- Research
- Education
- Workforce Development

- Applications
- Collaborations
- Integration of Quantum Computers with Classical HPC Centers



## Selected Partnerships

QAIventures

QED-C

CHICAGO QUANTUM EXCHANGE



QM QUANTUM MACHINES

INTESA SANPAOLO

links FONDAZIONE PASSION FOR INNOVATION

bip.



WOLFRAM



NERSC

Los Alamos NATIONAL LABORATORY



MIT Massachusetts Institute of Technology



# Commercial Results



## Optimization

“I wanted to send a big big thank you for making our experiments on the **beautiful Aquila device** possible!  
Results are here:  
<https://arxiv.org/abs/2308.13607>”

## Deloitte.

## Machine Learning

Classification of manufacturing defect images from smart factory data using QuEra’s QRC algorithm show an **11.24% improvement** over classical methods.

## Global Energy Company

## Optimization

“Using QuEra’s encoding, we expect to be able to run optimization programs that are **50% larger** than we were able to run on D-Wave”



# QuEra: Innovation Ecosystems



## Basel (Svizzera)

# QAIventures

- Access to QuEra's Computers
- Education on Quantum
- Consulting on Projects and Applications



## UK

# leap<sup>w</sup>



- Design of new drugs for rare genetic diseases – Wellcome Leap



## National Quantum Computing Centre

- **QuEra Computer to be installed on prem in 2025**
- Opening of an Office in the UK
- Hiring of qualified employees

# QuEra's machines on Premises



Japan

# Talk to us!

## ✔ Fundamental Research and Applications

- Develop scientific collaborations
- Explore a wide spectrum of applications

## ✔ Researchers and middleware developers

- Explore QEC and optimize the software stack

## ✔ Opportunities at QuEra

- We are hiring!

### Join our **access waitlist**

<https://www.quera.com/waitlist>



### Contact us

<https://www.quera.com/contact-us>



### Explore our open positions

<https://www.quera.com/careers>

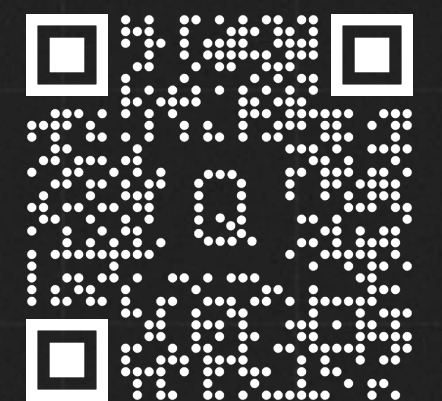

Q.ERA

#TheBestWayToQuantum

**Thank you!**



Tommaso Macri

[tmacri@quera.com](mailto:tmacri@quera.com)